



FRENCH FITNESS

FF-E620T

**FRENCH FITNESS E620T ELLIPTICAL W/15"
TOUCH CONSOLE (NEW)**

OWNER'S MANUAL



! CAUTION

Read all precautions and instructions in this manual before using this equipment.

FEATURES

- Brand: French Fitness
- Touchscreen console: built for a more premium, connected cardio experience
- Connected features: apps, online entertainment access, screen mirroring, and virtual scenery
- Training modes: HRC plus four preset programs: Hill, Interval, Cardio, and Fat Burn
- Power requirement: requires external power
- Max user weight: 160 kg / 353 lbs
- Product dimensions: 742 x 2113 x 1610 mm

TECH SPECS

- Product Name: French Fitness E620T Elliptical w/ 15.6" TFT Touchscreen Console
- Product Code: E620T
- Certification: CE
- Max User Weight: 160 kg / 352 lbs
- Electrical Receptacle & Plug: 220V-240V
- Power Supply: 60W
- Brake Type: Self Powered Hybrid Brake
- Resistance Brake Power: 350W
- Resistance Levels: 25
- Stride Length: 533 mm / 21"
- Pedal: Pedal with cushioned gel pads
- Pedal Spacing: 1"
- Step-up Height: 190 mm / 7.5"
- Handlebar Control: Handlebar Control; ABS+TPU coated handlebars
- Console Display: 15.6" TFT
- Console Readouts: Resistance, time, distance, calories, HR, RPM
- Language: EN/CN/FR/DE/ES/PT/IT/RU/JP/KR
- Metric/English: Metric&English
- Entertainment: Multiple built-in apps
- Programs: 5
- HR Monitor: Contact&Telemetry
- Accessory Storage: Yes
- USB Data Exchange: Yes
- Multi-language Display: Yes
- Gross Weight: 174.9 kg / 385.6 lbs
- Net Weight: 118 kg / 260.1 lbs
- Product Dimensions: 742 x 2113 x 1610 mm
- Product Dimensions (Imperial): 29.2" x 83.2" x 63.4"

WARRANTY

- **Lifetime Frame Warranty**
- **10 Years Parts Warranty***
- **1 Year Labor Warranty***

*What is covered? See complete [French Fitness Warranty](#) details.

Table Of Contents

IMPORTANT SAFETY INSTRUCTIONS.....	4
SUBASSEMBLY PARTS LIST	6
CONSOLE PANEL FUNCTIONS	7
TROUBLESHOOTING GUIDE	38
ELECTRICAL CONNECTION	39
MAINTENANCE CHECK LIST	40

Important Safety Instructions

WARNING! The safety of the product can be maintained only if it is examined regularly for damage and wear. See preventive maintenance section for details.

WARNING! Heart rate monitoring systems may be inaccurate. Over exercising may result in serious injury or death. If you feel faint stop exercising immediately.

LOCATION

1. Keep the area around the product clear of any obstructions, including walls and furniture. Provide at least three feet of clearance behind the unit.
2. Do not use the product outdoors, near swimming pools, or in areas of high humidity.
3. Do not allow other people to interfere in any way with the user or equipment during workout.
4. this appliance is not intended for use by persons (including children) with reduced physical, sensory or mental capabilities, or lack of experience and knowledge, unless they have been given supervision or instruction concerning use of the appliance by a person responsible for their safety.
5. children should be supervised not to play with the appliance.
6. The product should only be used on a level surface and is with 0.6 meters space around the product.

OPERATION

1. Always follow the console instructions for proper operation.
2. Do not reach into, or underneath, the unit, and do not tip the unit on its side during operation.
3. Never insert objects into any opening of the Bike. If any object fall into this equipment, carefully retrieve it while the unit is not in use. If the object can't be reached, please contact customer services.
4. Never place any containers filled with liquids on the unit, except in the accessory tray or water bottle holder. Containers should be covered with lids.
5. Wear shoes with rubber or high-traction soles. Do not wear shoes with high heels, leather shoes, slippers, or spikes. Make sure no sharp stuff is embedded in the soles.

Important Safety Instructions

6. Do not use the bike with bare feet.
7. Keep all loose clothing, shoelaces, and towels away from moving parts.
8. Take extra caution when stepping on or off the bike.
9. Never face backward while using the bike.
10. the appliance is only to be used with the unit provided.
11. If the cord set is damaged, it must be replaced by a special cord set available from the manufacturer or its service agent.

Save these instructions for future reference

Training Area and Free Area

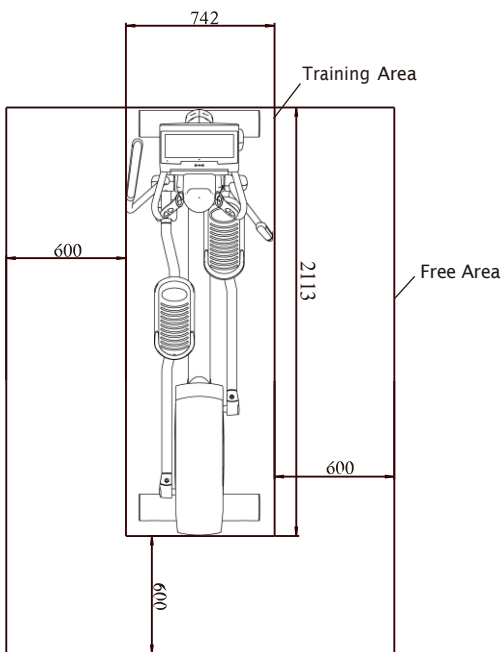

Specifications

Class: SB

Maximum User Weight: 160kg/ 353lbs

Product Dimension: 742*2113*1610mm

Product Total Surface: 742*2113mm

Product Total Mass: 118kg/ 260lbs

Warm Up Exercises

EXERCISE GUIDELINES

WARNING! Before beginning this or any exercise program, you should consult your physician. This is especially important for individuals over the age of 35 or individuals with pre-existing health problems.

Warming up prepares the body for the exercise by increasing circulation, supplying more oxygen to the muscles and raising body temperature. Begin each workout with 5 to 10 minutes of stretching and light exercise to warm up. The photos on this page show several forms of basic stretching you may perform before your workouts. In order to achieve an adequate warm-up, perform each stretch three times.

TOE TOUCH STRETCH

Stand, bending your knees slightly and slowly bend forward from your hips. Allow your back and shoulders to relax as you reach down toward your toes as far as possible. Hold for 15 counts, then relax. This will stretch your hamstrings, back of knees, and back.

HAMSTRING STRETCH

Sit with one leg extended. Bring the sole of the opposite foot toward you and rest it against the inner thigh of your extended leg. Reach toward your toes as far as possible. Hold for 15 counts, then relax. This will stretch your hamstrings, lower back, and groin.

CALF/ACHILLES STRETCH

With one leg in front of the other, reach forward and place your hands against a wall. Keep your back leg straight and your back foot flat on the floor. Bend your front leg, lean forward and move your hips toward the wall. Hold for 15 counts, then relax. To cause further stretching of the achilles tendon, bend your back leg as well. This will stretch your calves, achilles tendons, and ankles.

QUADRICEPS STRETCH

With one hand against a wall for balance, reach back and grasp one foot with your other hand. Bring your heel as close to your buttocks as possible. Hold for 15 counts, then relax. This will stretch your quadriceps and hip muscles.

INNER THIGH STRETCH

Sit with the soles of your feet together and your knees outward. Pull your feet toward your groin area as far as possible. Hold for 15 counts, then relax. This will stretch your quadriceps and hip muscles.

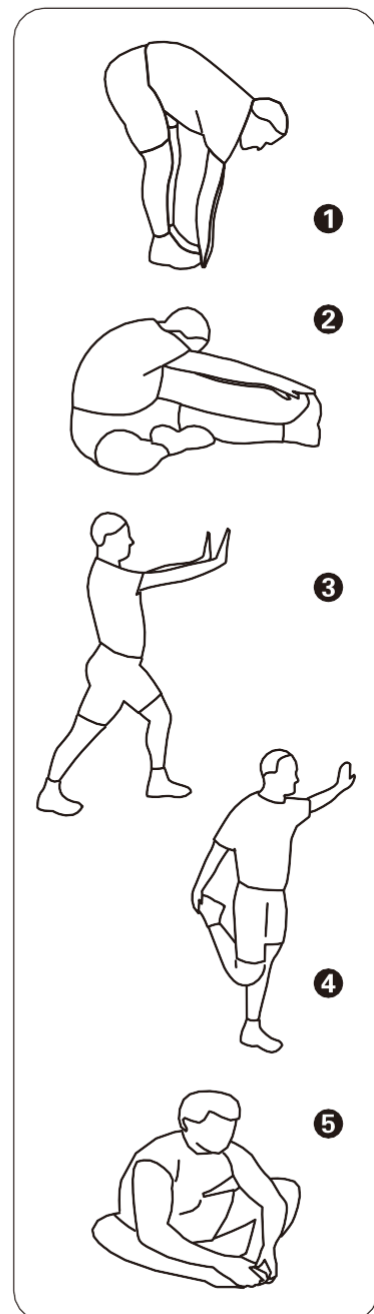

Console Panel Functions

Home Page and Button Instructions

Home page: The home page displays the following functions:

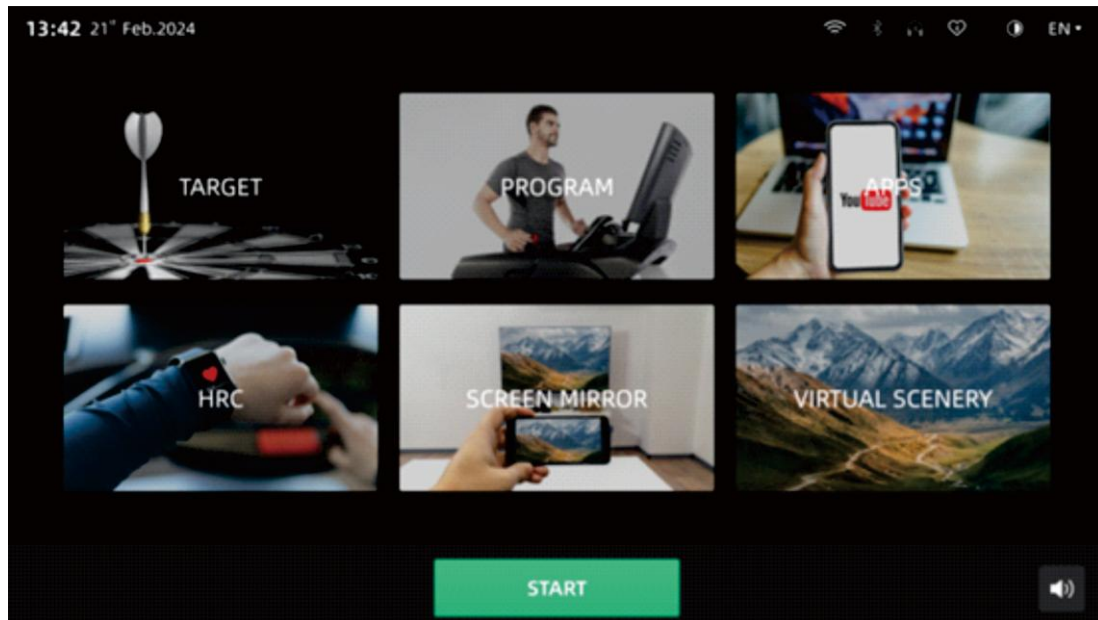

START: Press Start to start ride.

TARGET: To set ride goals based on time, distance, and calories.

PROGRAM: Workout according to four preset programs: hill, interval, cardio, and fat burning.

APPS: Online entertainment including listening to music, watching videos and surfing requires internet connection.

HRC: Set a target heart rate and move closer to it by automatically adjusting the resistance.

SCREEN MIRROR: It can be used for Android and Apple screen casting.

VIRTUAL SCENERY: Users can choose to run in different scenarios. **SETTINGS:** System related settings, including internet, Bluetooth, general settings, device information and language, etc.

Console Panel Functions

Target

Press "TARGET" on the home page and select the mode from "Time", "Distance" and "Calories". Scroll the red bar or press the +/- buttons to set age, weight and ride data. Press the Start button to begin riding. Once the user reaches the set goal, the bike will stop automatically.

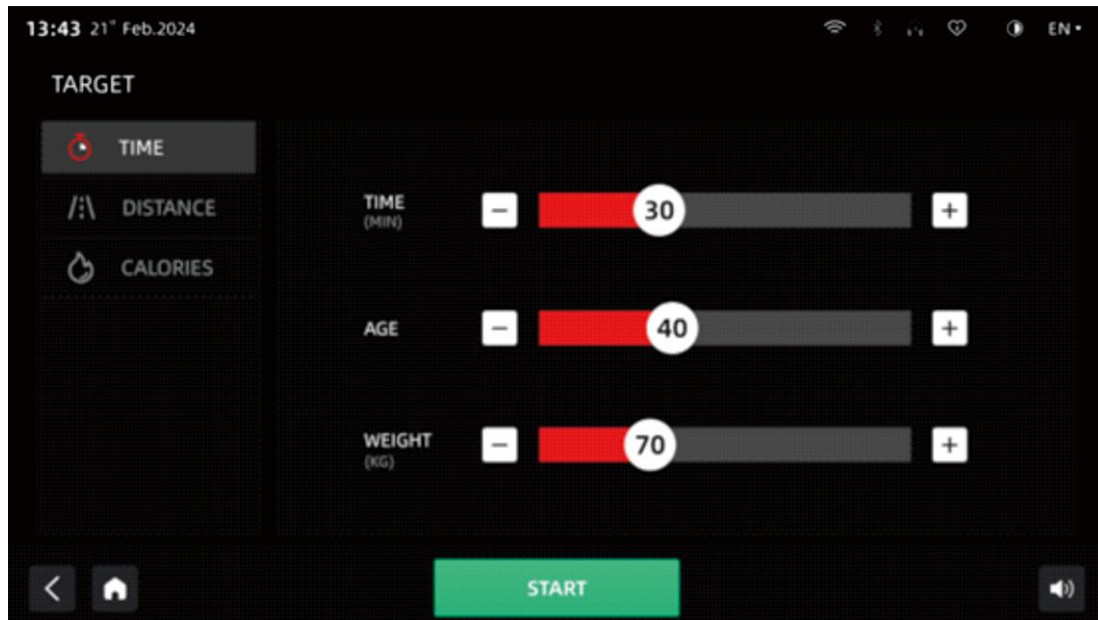

Set exercise goals based on time

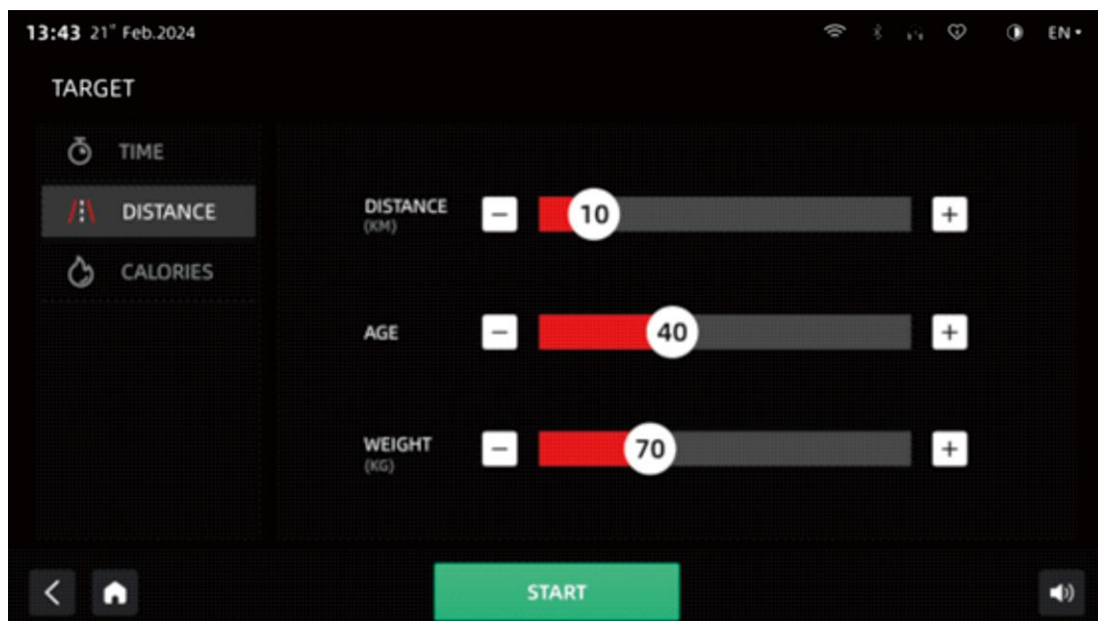

Set exercise goals based on distance

Console Panel Functions

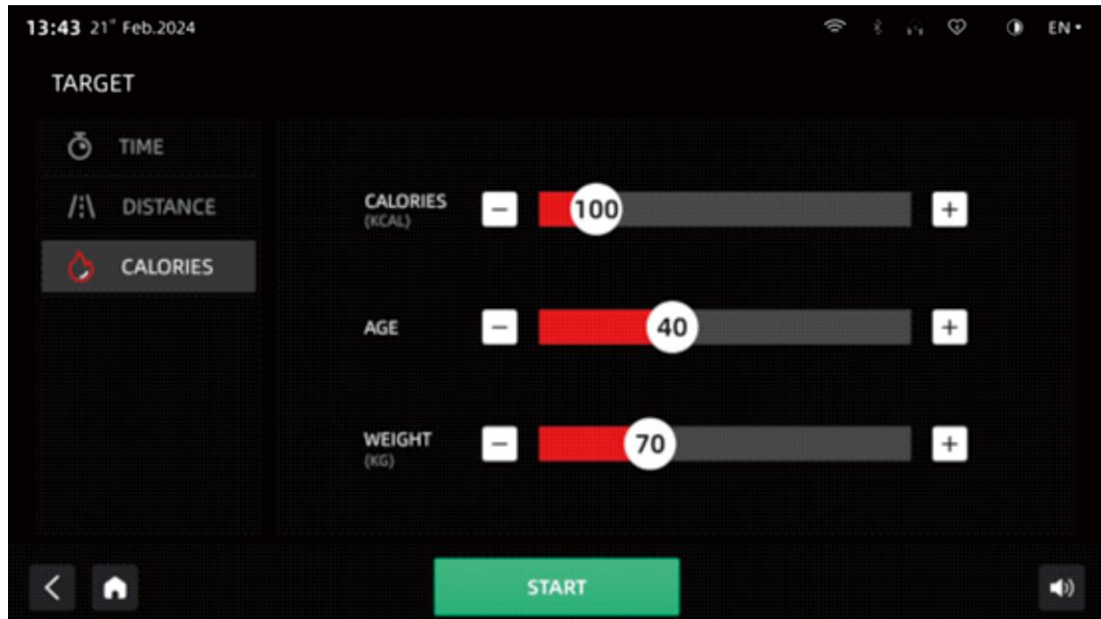

Set exercise goals based on calories

START

Press START on the home page to enter the Cycling page.

When pressed, the display will show a countdown of 3, 2, 1 and GO. When the sound ends, the bike will enter the riding phase.

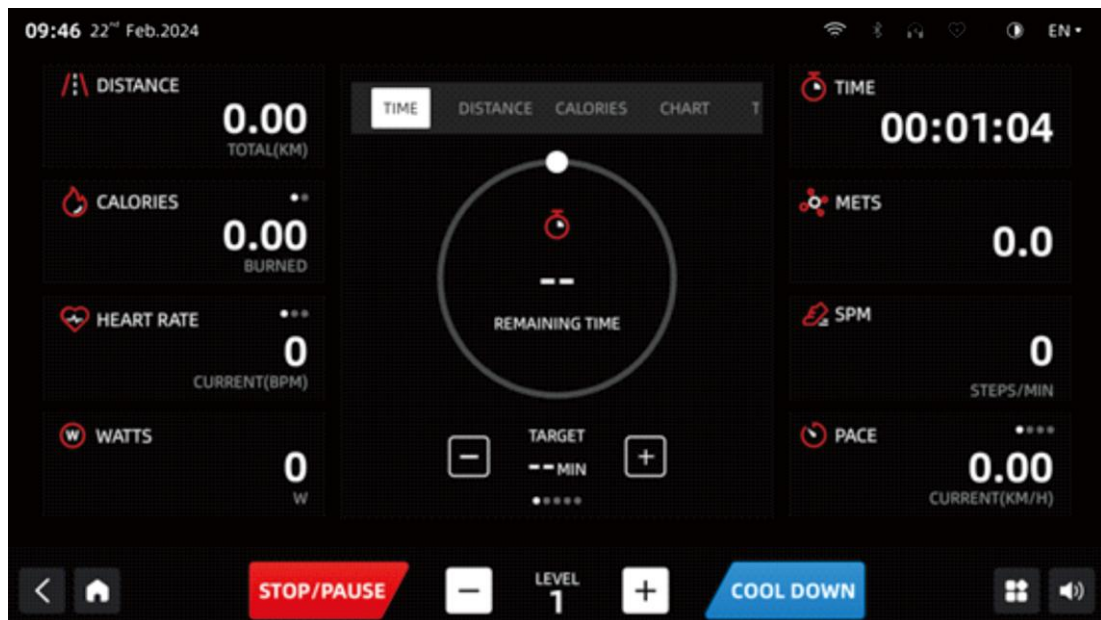

ride page

Console Panel Functions

Resistances

While the bike is ride, you can adjust the resistance by pressing the up and down icons directly below the screen, which can be set with a single click.

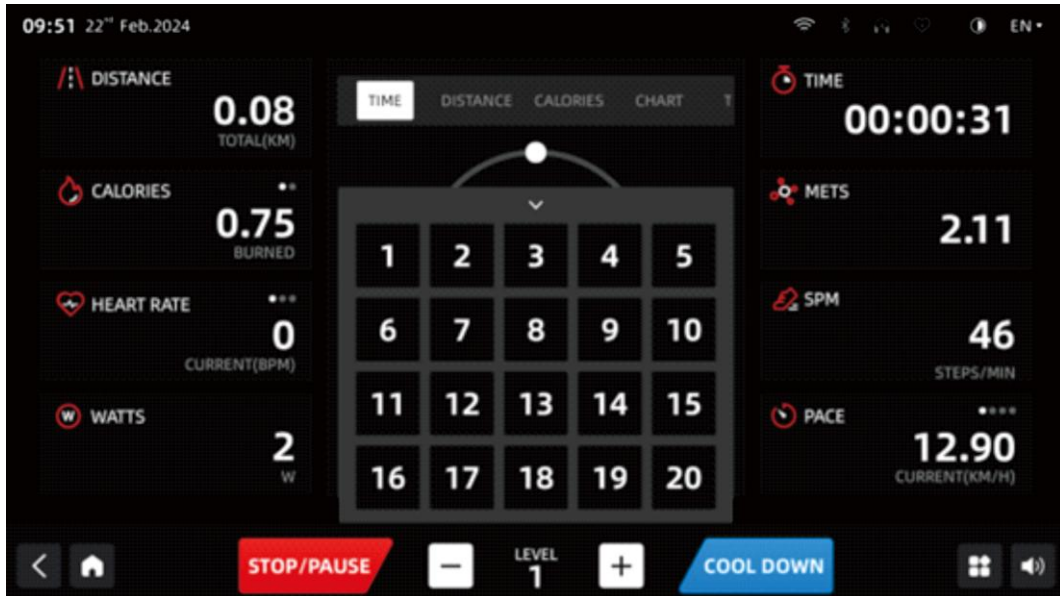

resistances

Cool Down

Entering the ride page, press COOL DOWN to cool down. This program will have the speed and display a countdown of three minutes. The relaxation time of three minutes is not included in the exercise report.

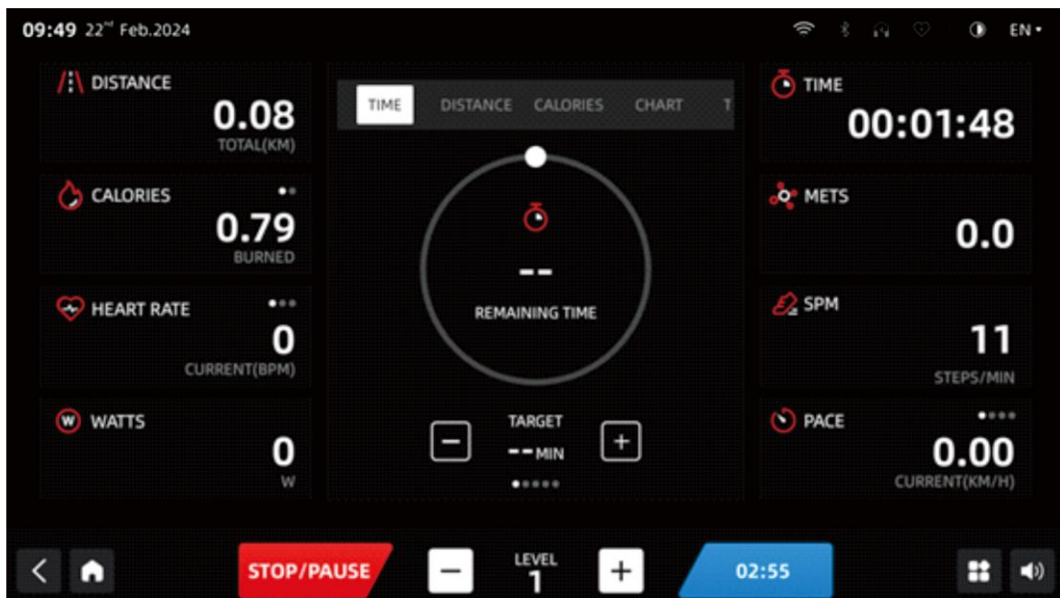

Cool down

Console Panel Functions

STOP

Enter the ride page and press STOP button to stop the bike. It will end with a page displaying time, distance, and calories burned of this exercise. The data will show changes in heart rate, incline and speed. Users can press STOP button to stop the current exercise, and press RESUME button to continue this exercise.

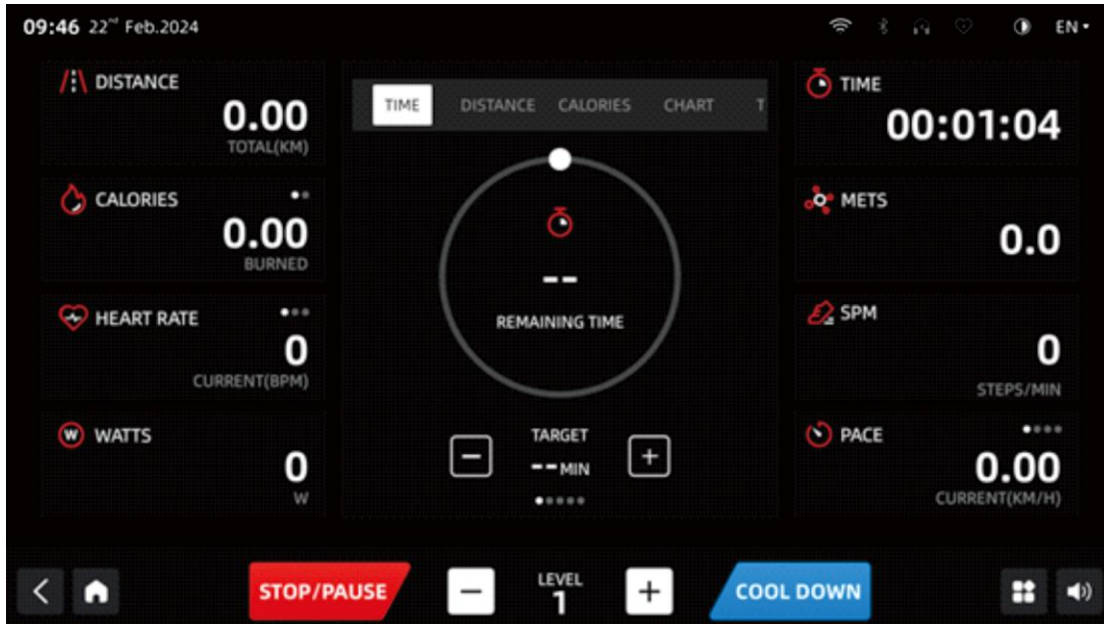

Ride page

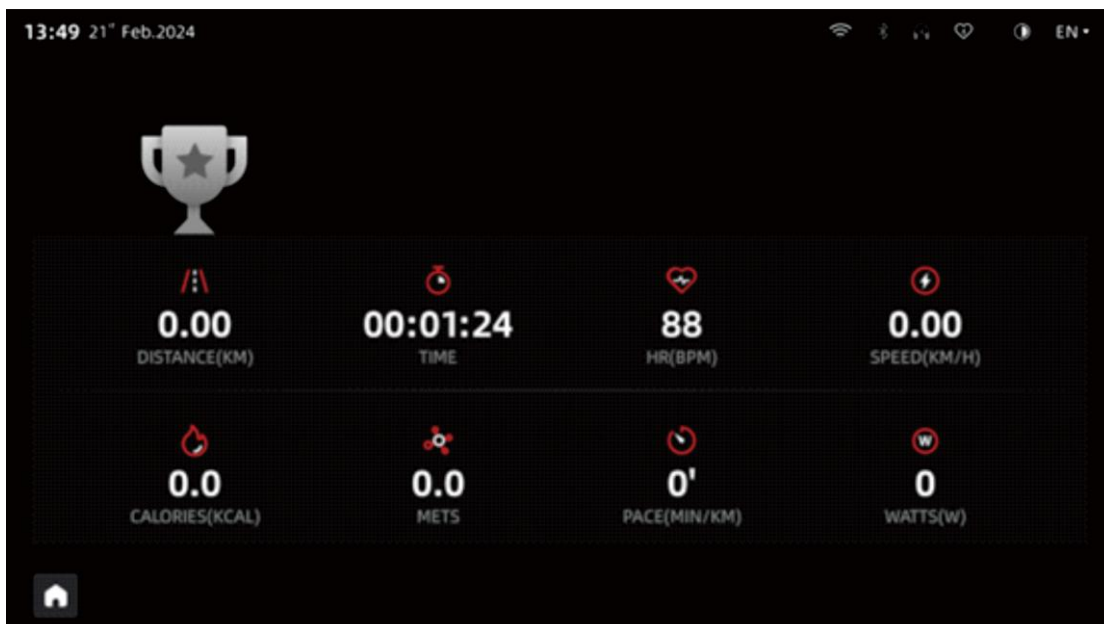

Exercise report

Console Panel Functions

Other Buttons on the ride Page

"Home/Back" button: When user go back to the home page, the exercise page will also shrink to display on the home page. User can change language on the home page. You can also switch to other modes, such as HILL, and it will pop up window to hint whether to switch.

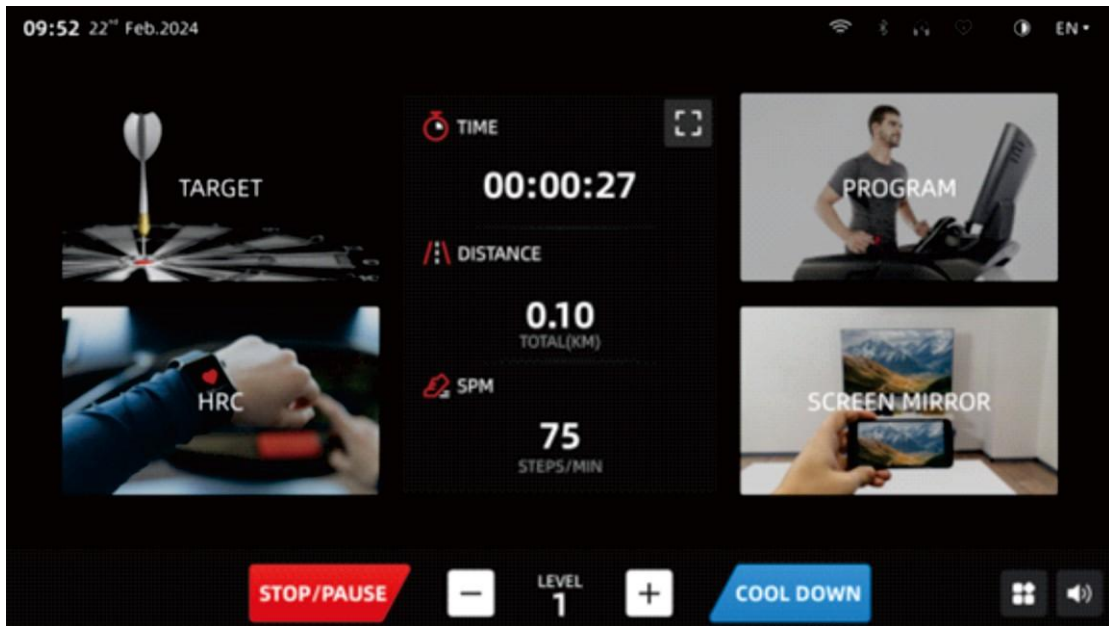

Press HOME or BACK

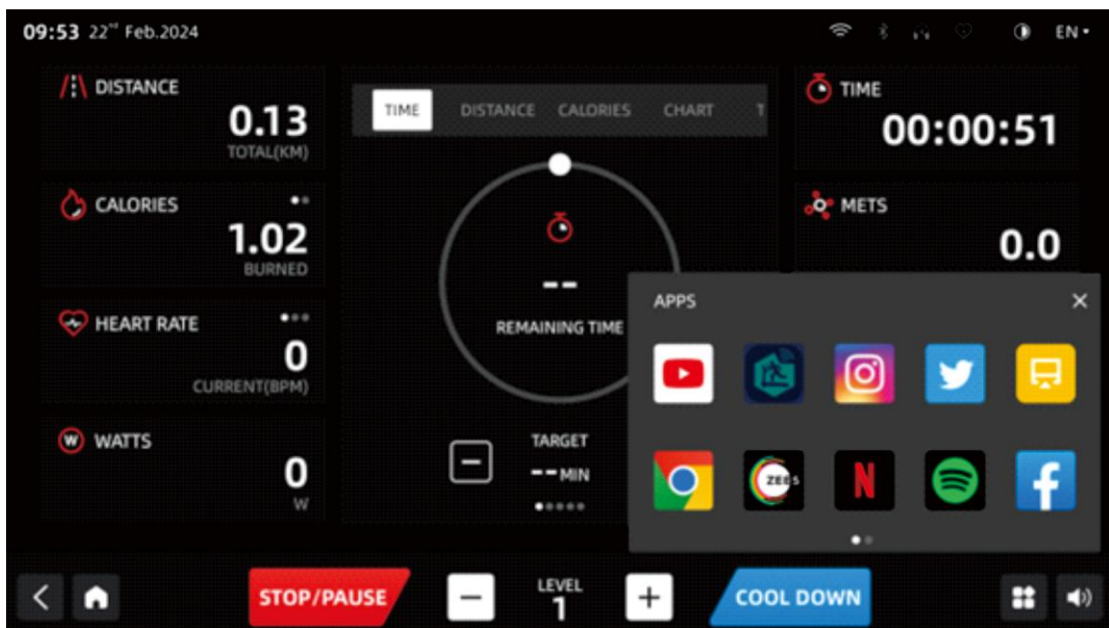

Press Entertainment icon

Console Panel Functions

Volume button: Press the speaker icon to adjust the volume

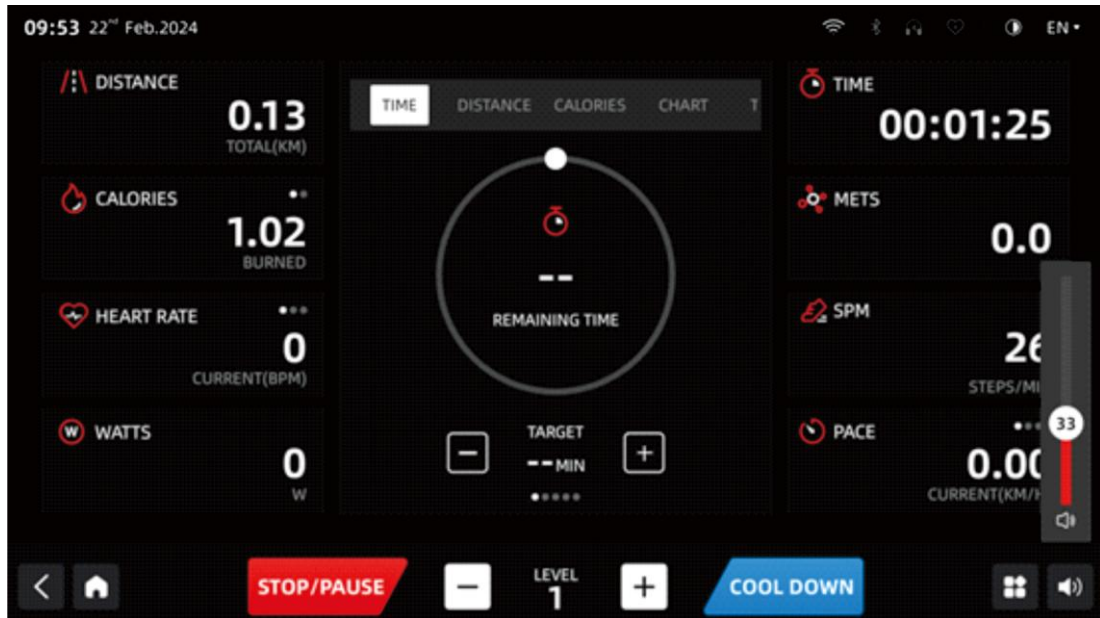

Press volume

Other control bar buttons: Press time +/- to adjust the exercise countdown time. Press distance +/- to adjust exercise distance. Press calories, set weight first, then press +/- to adjust exercise countdown calories. Press CHART to display speed/incline in icon mode. Press TRACK to display runway mode. (The bike will stop ride when it reaches the current set target (distance/time/calories)).

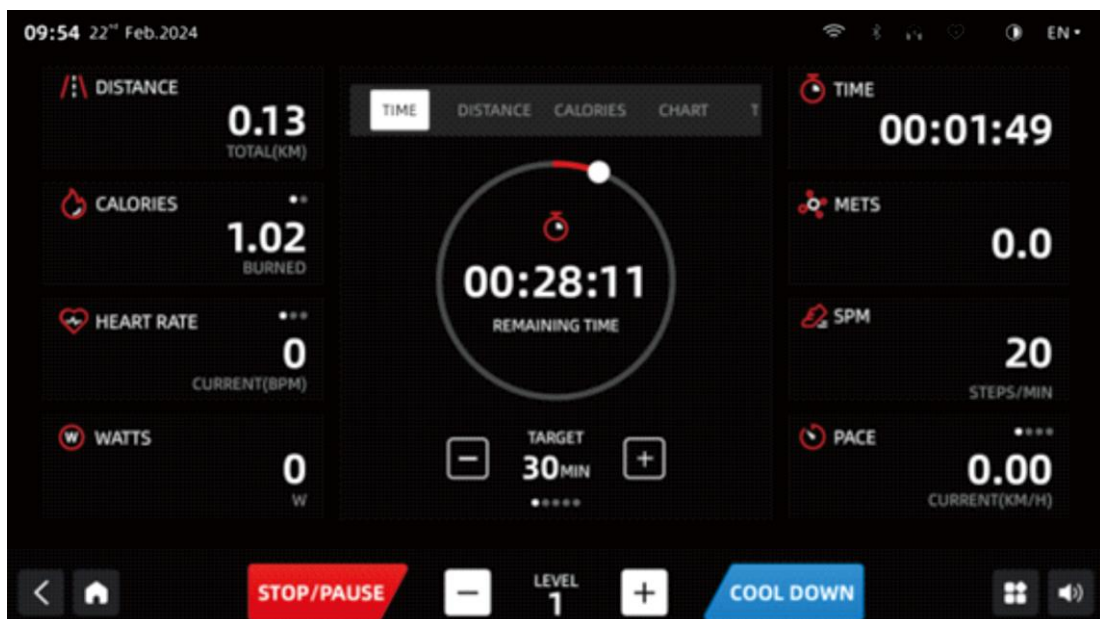

Press TIME

Console Panel Functions

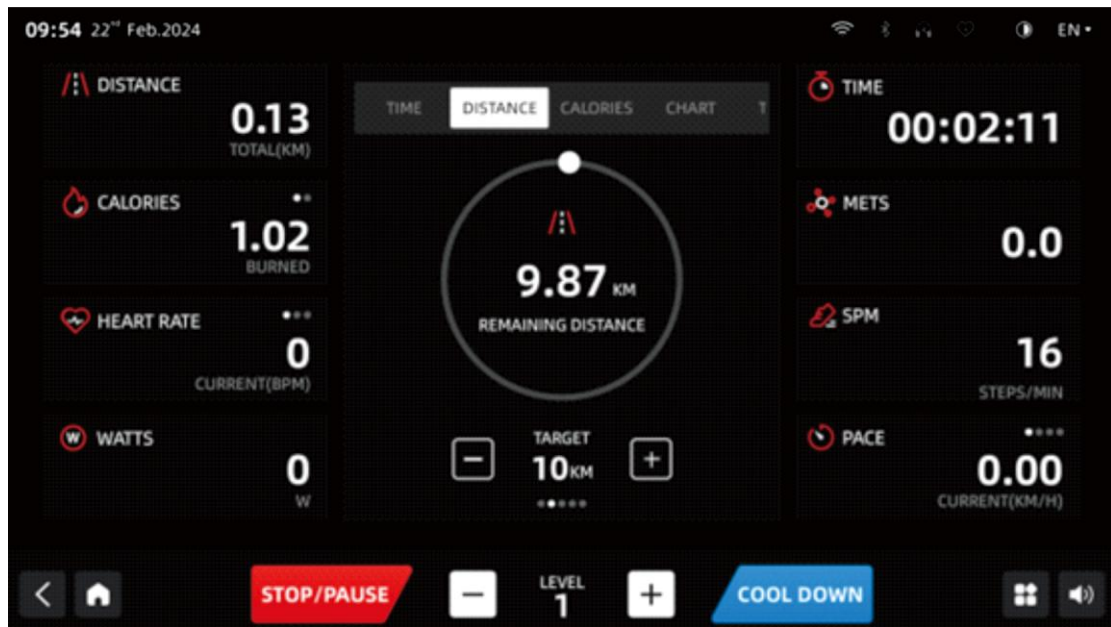

Press DISTANCE (Imperial)

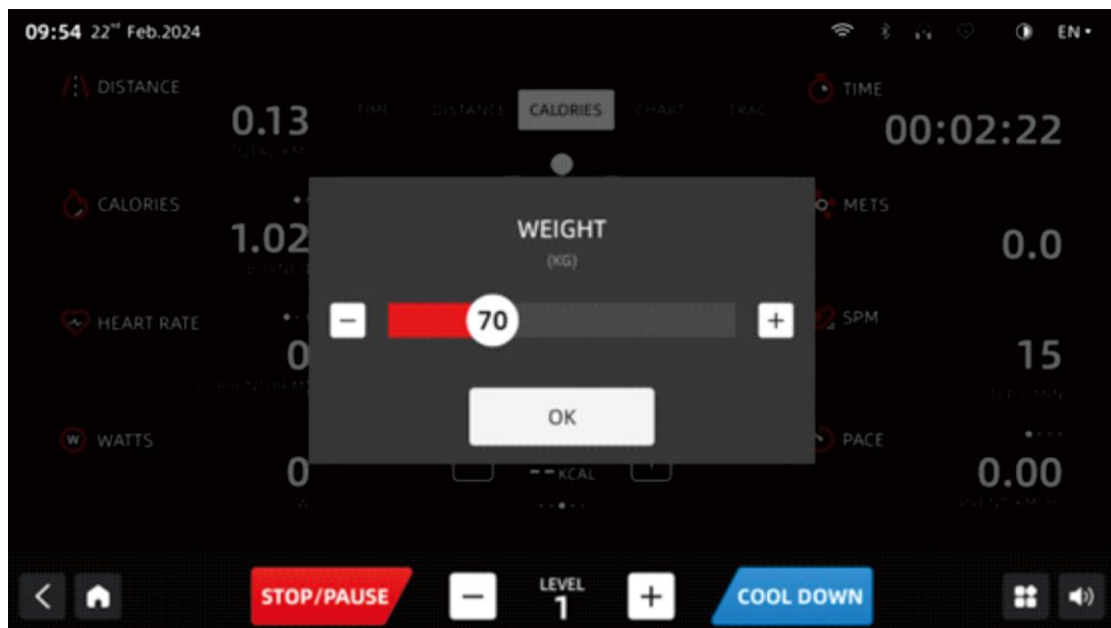

Press CALORIES (set weight)

Console Panel Functions

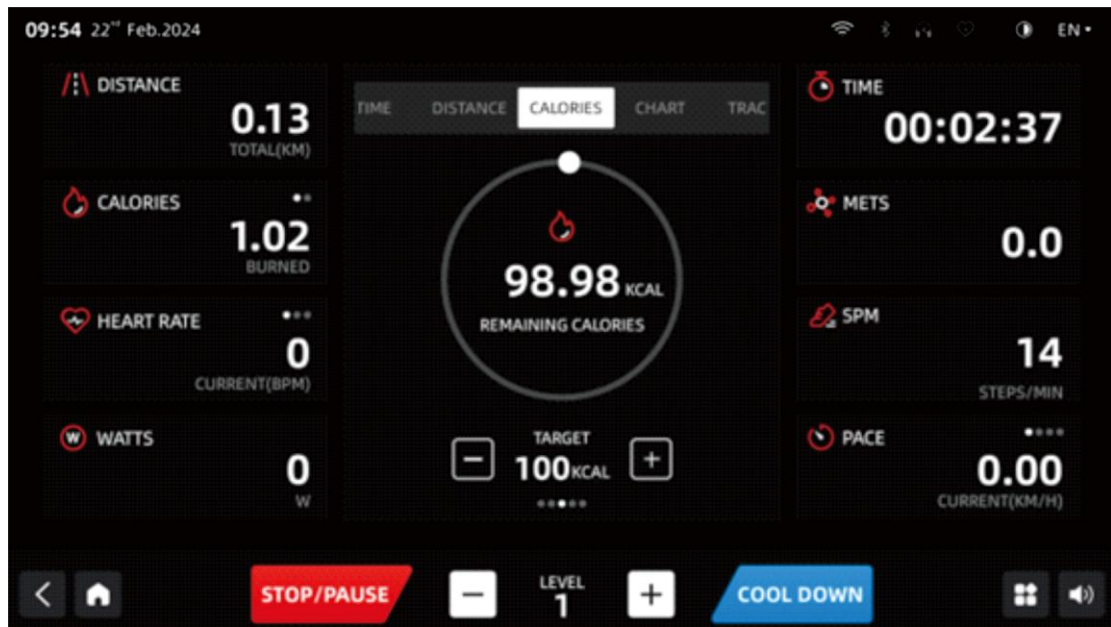

Press CALORIES

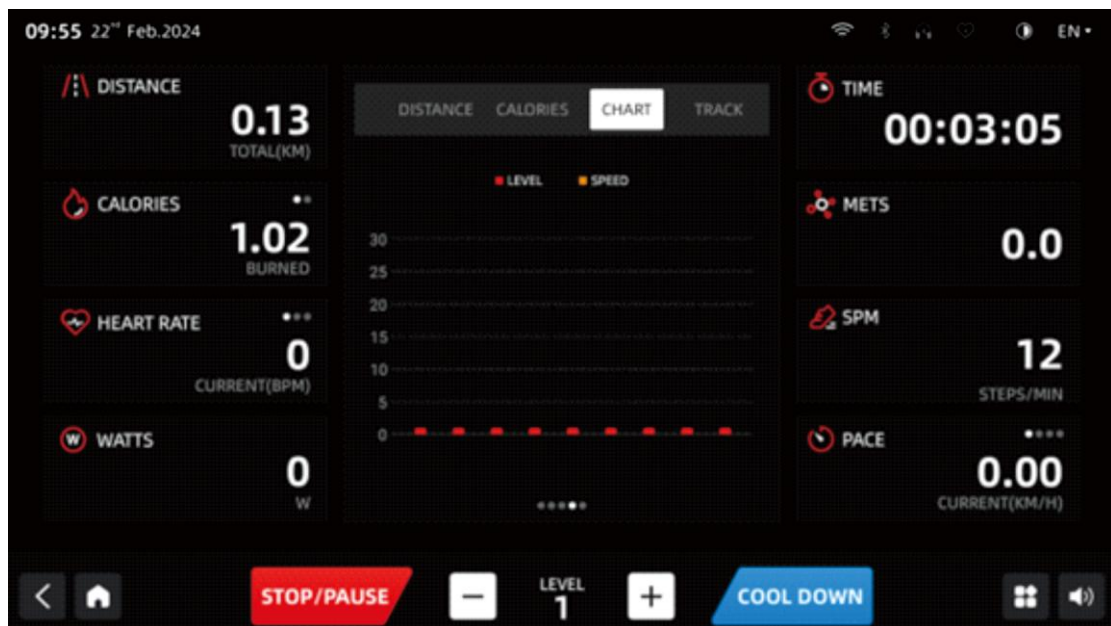

Press CHART

Console Panel Functions

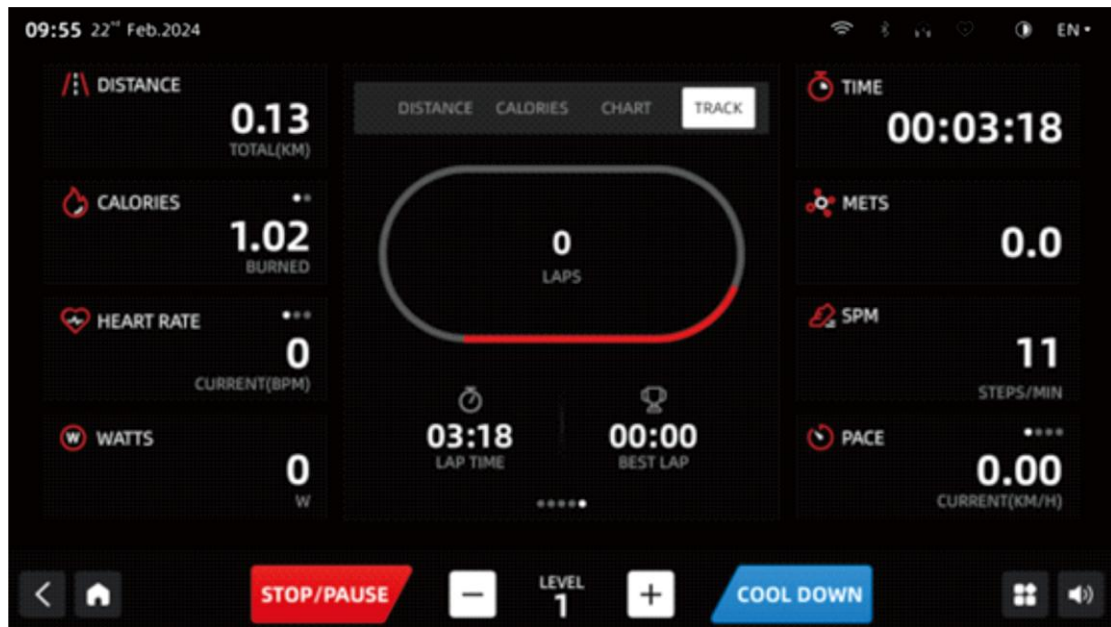

Press TRACK

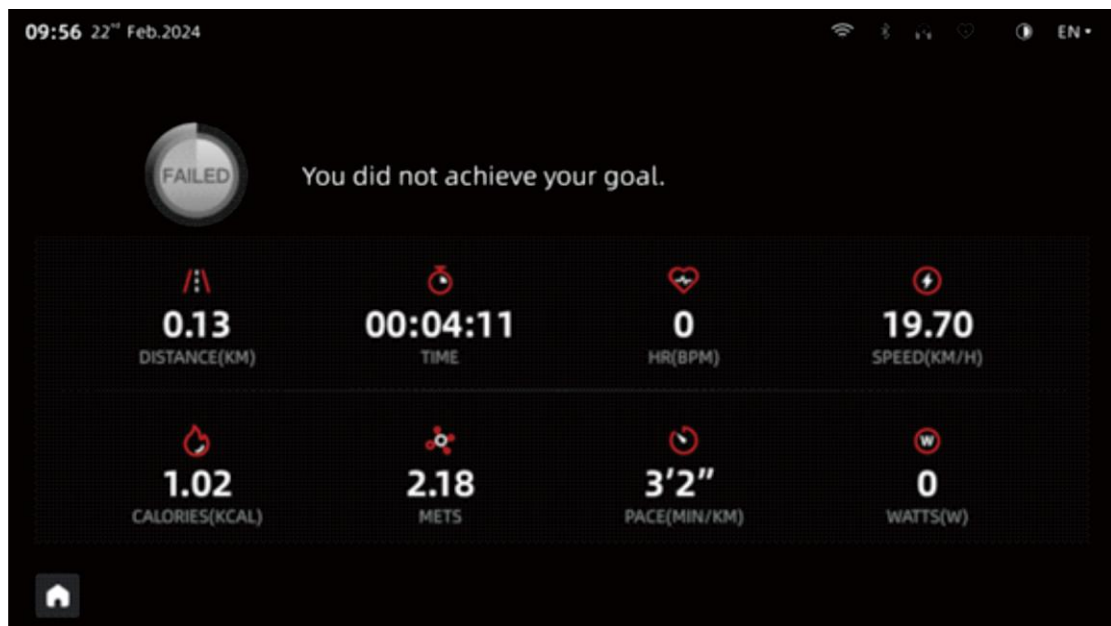

Exercise ending

Console Panel Functions



Real-time heart rate, average heart rate, maximum heart rate of this exercise,



Real-time speed of this exercise. Swipe left to display the average pace and average speed,



Real-time distance of this exercise. Swipe left to display climbed distance,



Real-time metabolic rate of this exercise,

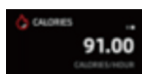

Real-time calories this exercise burned. Swipe left to display calories/hour,

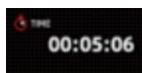

Duration of this exercise.



Displays the frequency of feet per minute

APPS

Press APPS on the home page to enter the applications interface. You need to connect to the internet to access these platforms. You can also Press "APPS" icon in the lower right corner of the ride page. Video - YouTube; Music - Spotify; Browser - Google Chrome; GymTrakr, Instagram, Twitter, Screen Mirror, ZEE5, Netflix, Facebook and so on.

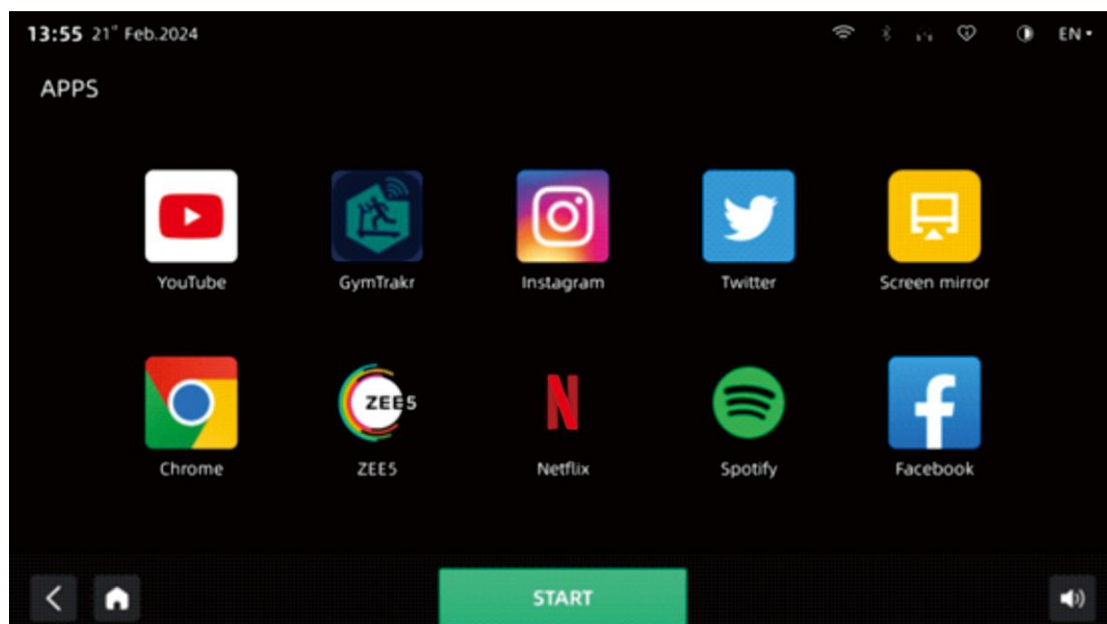

Console Panel Functions

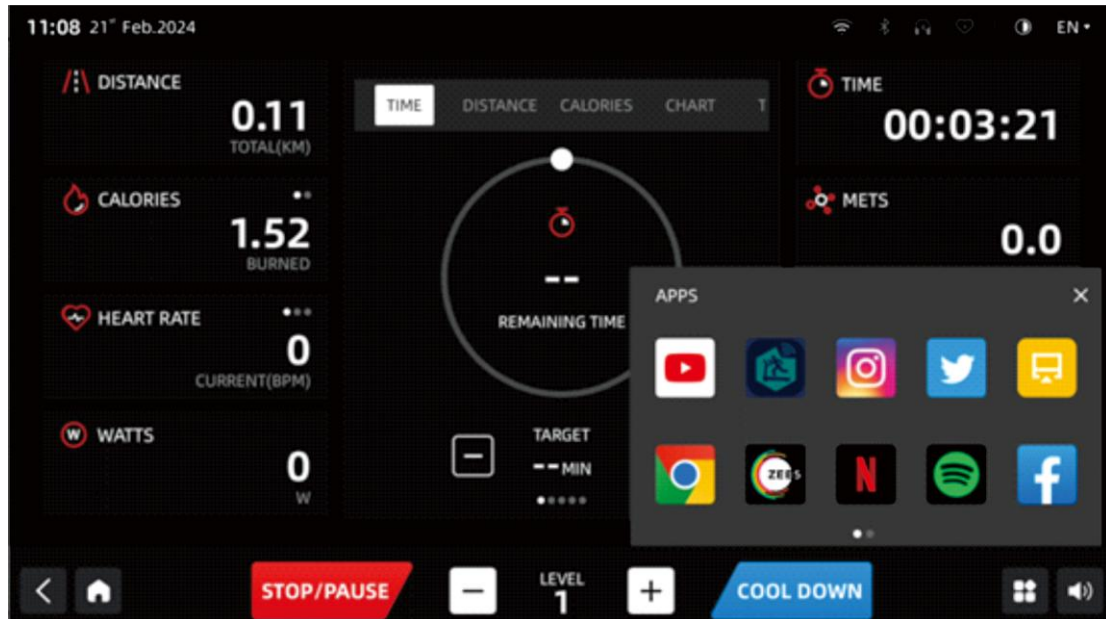

Entertainment page - internet connected

If you want to display the ride page in full screen, press the white "  " button to hide the control bar. Press here again and the control bar will appear.



Console Panel Functions

Virtual Scenery

Press Virtual Scenery on the home page to enter the virtual scenery interface. Virtual scenery is the process of simultaneously playing scenery videos during the ride process, allowing users to have an immersive ride feeling. Users can choose the ride scene according to their preferences. Each scene mode has a fixed ride program (adjustable).

Virtual Scenery Page

Press any scenery mode to enter the ride page.

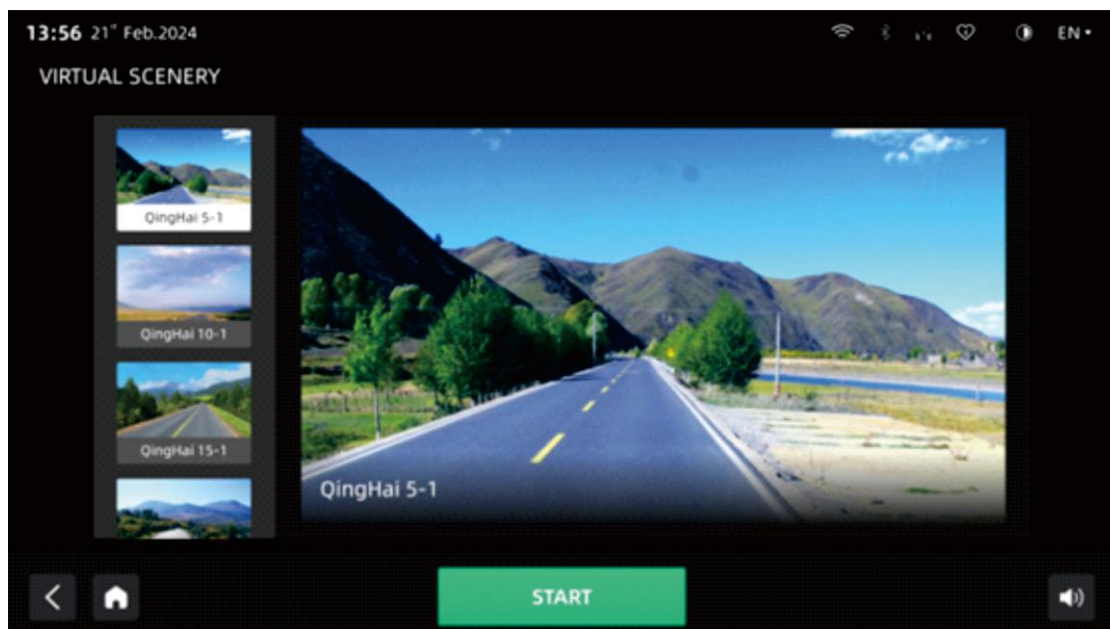

Video mode

PROGRAMS

Press "Program" to enter the program ride page. The system is preset with four exercise modes: HILL, INTERVAL, CARDIO, and FAT BURN.

Console Panel Functions

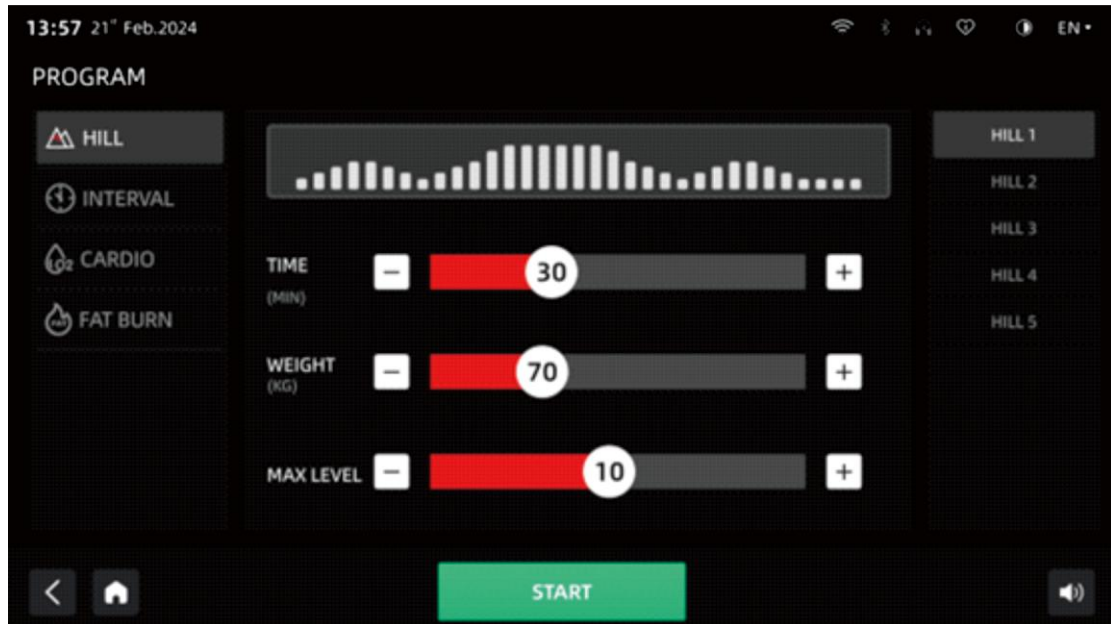

Program mode

Pre-set Programs:

After selection, you can view detailed exercise data, including time, distance, calories burned, and resistance at different time periods of this exercise.

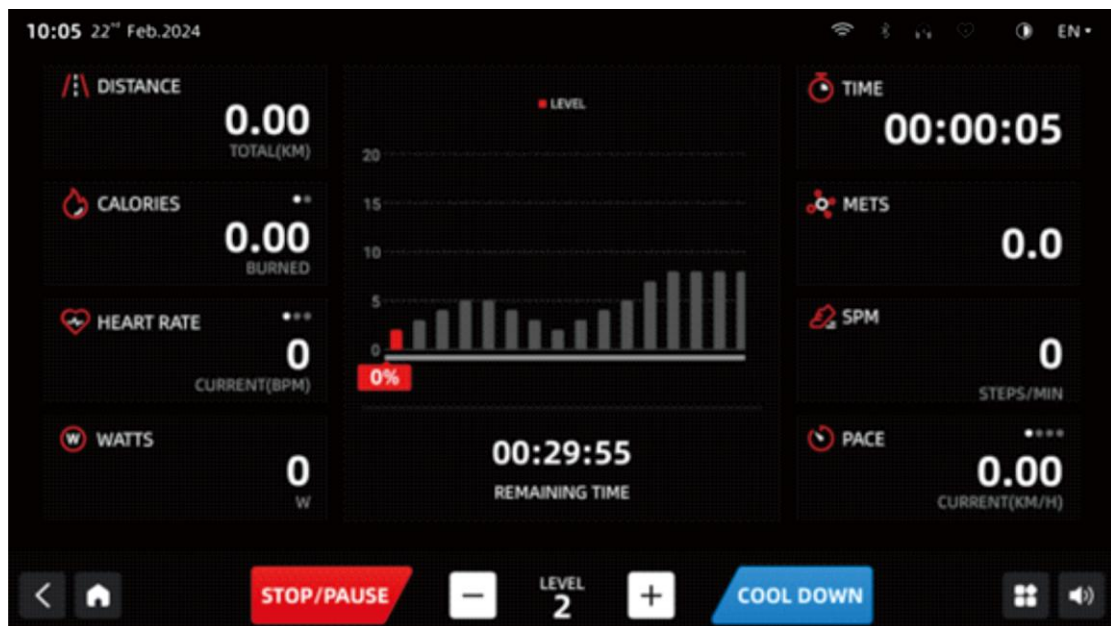

Pre-set program

Console Panel Functions

Custom Interval:

1. Press Interval to adjust the interval time, maximum/minimum speed, age and weight. According to personal exercise habits, you can choose exercise time and resistances to set up an exercise program, which can be composed of multiple exercise segments.
2. Press the Start button to start ride directly.

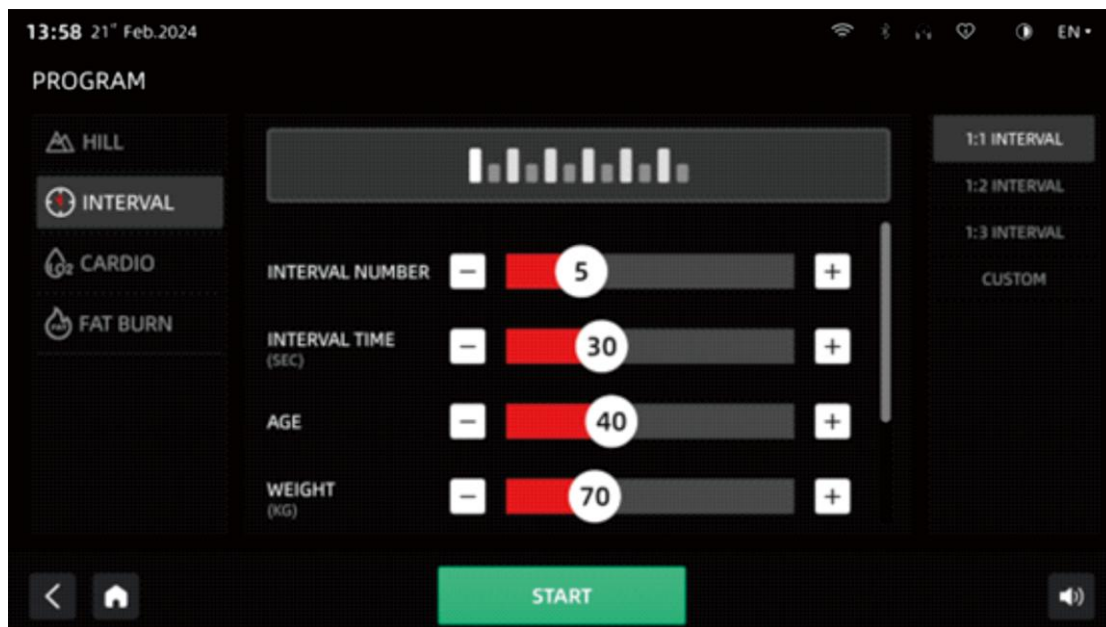

Custom interval

HRC

Click HRC, heart rate is divided into two modes, one is target heart rate one is interval heart rate.

Target heart rate - the default display value is $(220 - \text{age}) * 70\%$, users can adjust it by themselves, while the heart rate percentage is displayed as a reference value on the side.

For example: 40 years old, target heart rate = 126 (percentage 70%), heart rate is adjusted to 150 when (83%), the upper limit of adjustment is 180 BMP.

Target heart rate mode has a six-minute warm-up, with the program officially entering after six minutes.

Interval heart rate has a six-minute warm-up, with the first minute of the official start of the transition period.

- (1) The user's heart rate is not detected at the start: the resistance remain at the current settings until the heart rate is monitored or the workout is complete.
- (2) $\text{TARGET HR} - 3 \leq \text{user's heart rate} \leq \text{TARGET HR} + 3$: resistance remain unchanged, and move to the next exercise point.

Console Panel Functions

- (3) User's heart rate $<$ TARGET HR -3: resistance increases by 1 every 20s until the heart rate condition is met or the machine runs at maximum resistance.
- (4) The user's heart rate $>$ TARGET HR +3: the resistance decreases by 1 every 20s until the heart rate condition is met or the machine runs at minimum resistance.
- (5) If no heart rate is detected within 15 seconds, a pop-up window prompts "NO HR detected, Please use the contact HR grips or HR STRAP" with a beep.

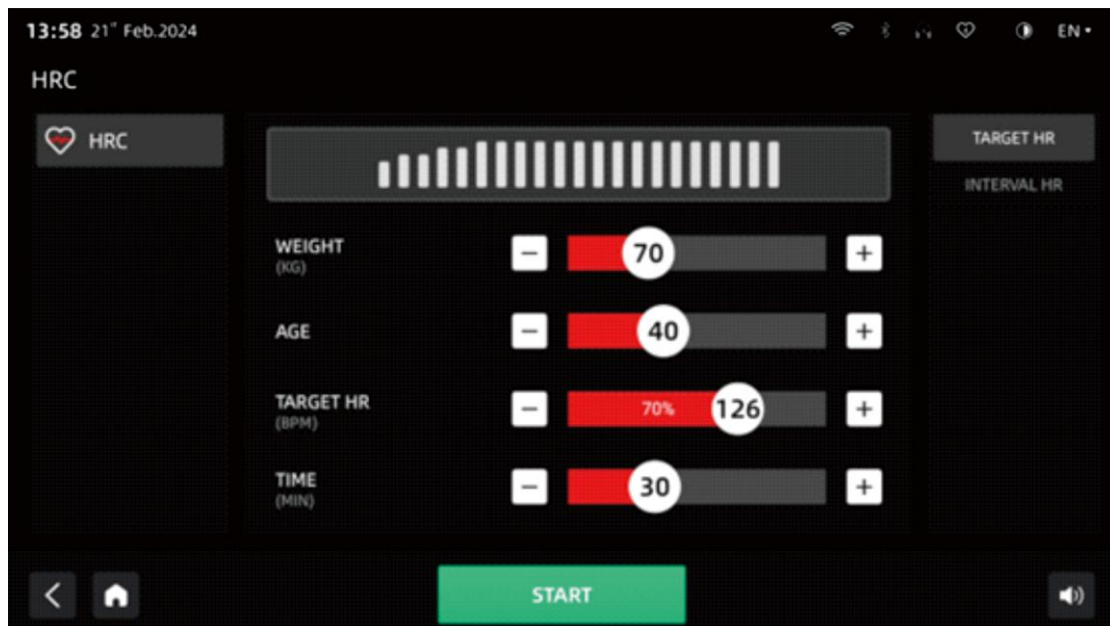

Target heart rate page

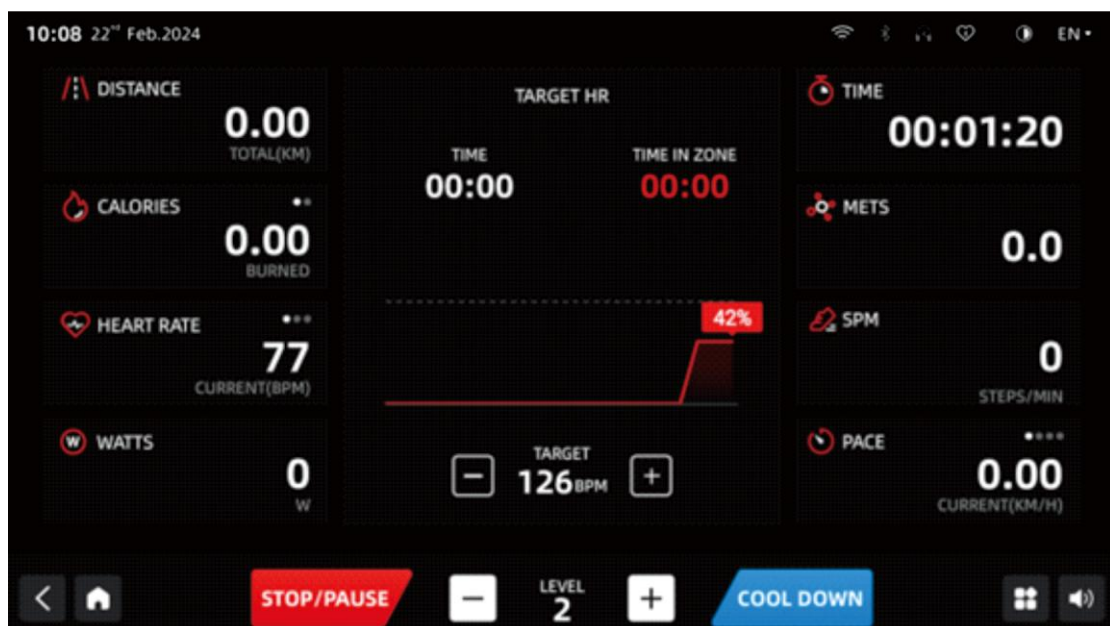

Heart Rate Riding Interface

Console Panel Functions

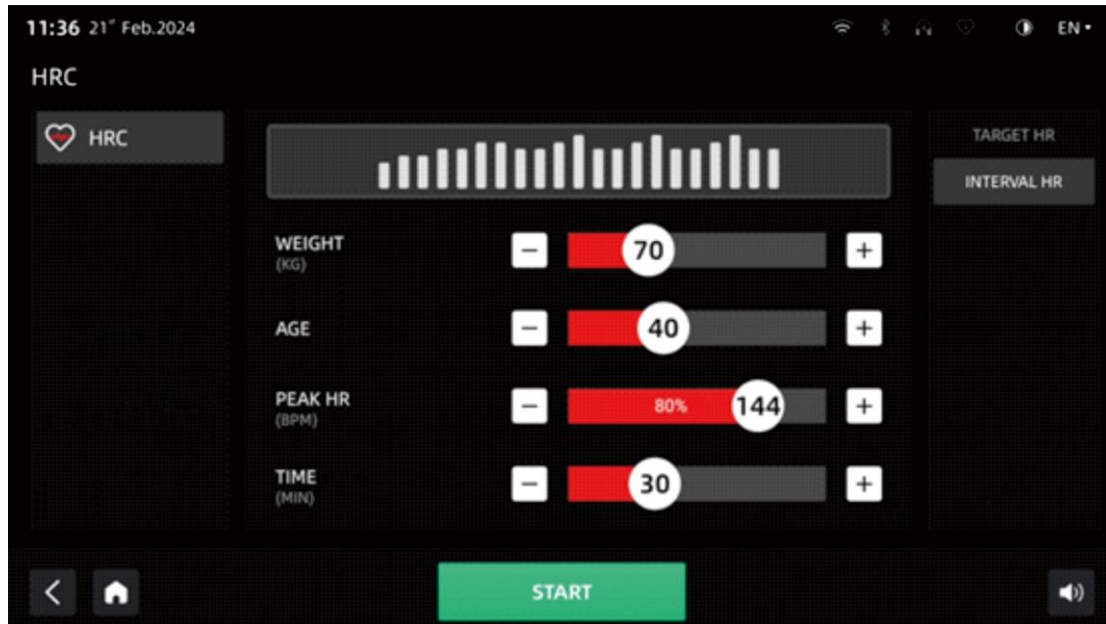

INTERVAL HR

Screen Mirror

Press Screen Mirror on the home page. The left side of the screen mirror page displays Android screen mirroring and the mirroring code, while the right side displays Apple screen mirroring and the mirroring code. For example, press the screen mirror on a Xiaomi phone, search for the Android screen mirroring code, press connected, then a connection message will appear on the screen indicating whether to accept it. Press accept to cast the screen. (The chat window on the phone will not be displayed on the treadmill screen)

Apple screen mirror: First connect to the WiFi displayed with the password 12341234, and then press the screen mirror on Apple's phone to enable Apple screen mirror.

Console Panel Functions

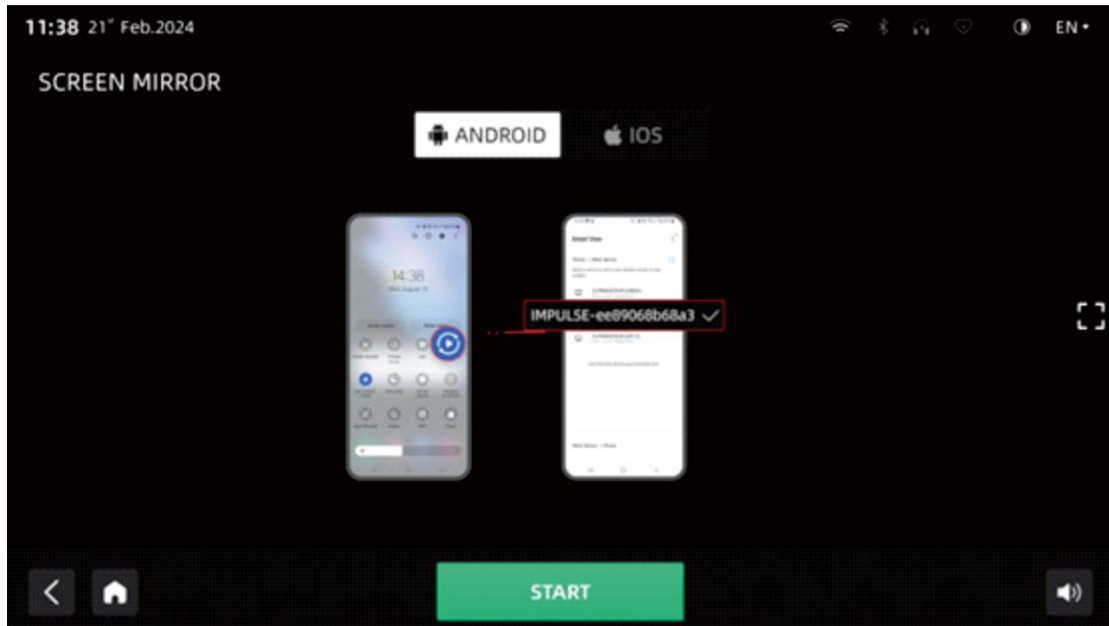

Screen Mirror page

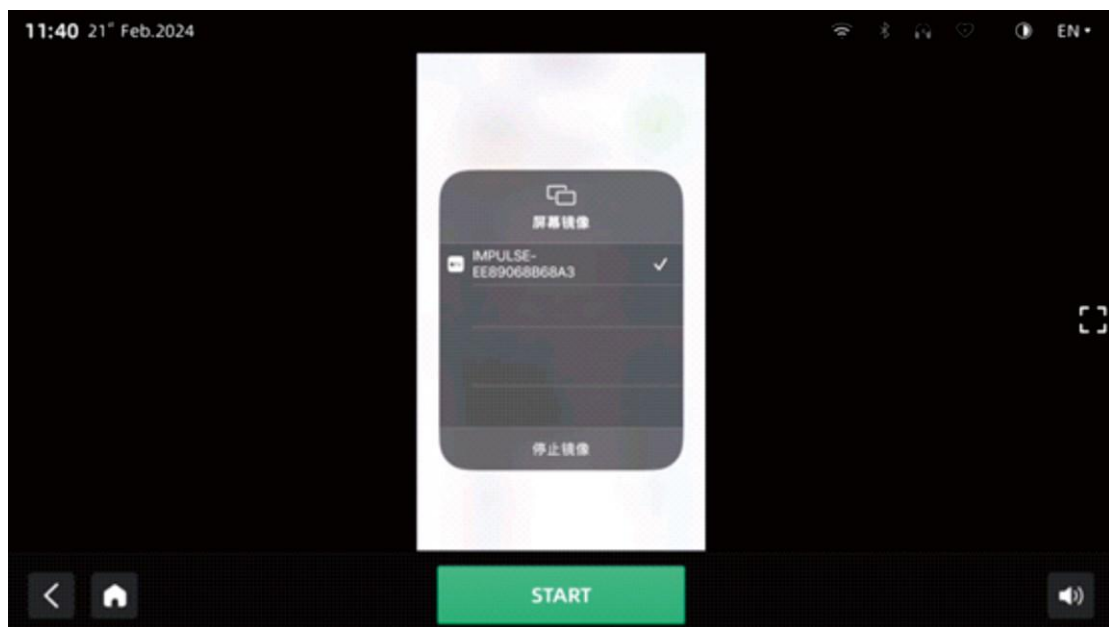

Apple screen mirror

Console Panel Functions

WiFi Settings

Press WiFi to display a WiFi pop-up window, open WiFi; it will display the available WiFi. Press the WiFi that needs to be connected, a pop-up window will appear. After entering the password, the system will automatically connect to the network, and prompt that the network connection is successful. If the internet cable is connected, the WiFi icon will disappear and become the network cable icon . Press other blank spaces and the WiFi will disappear.

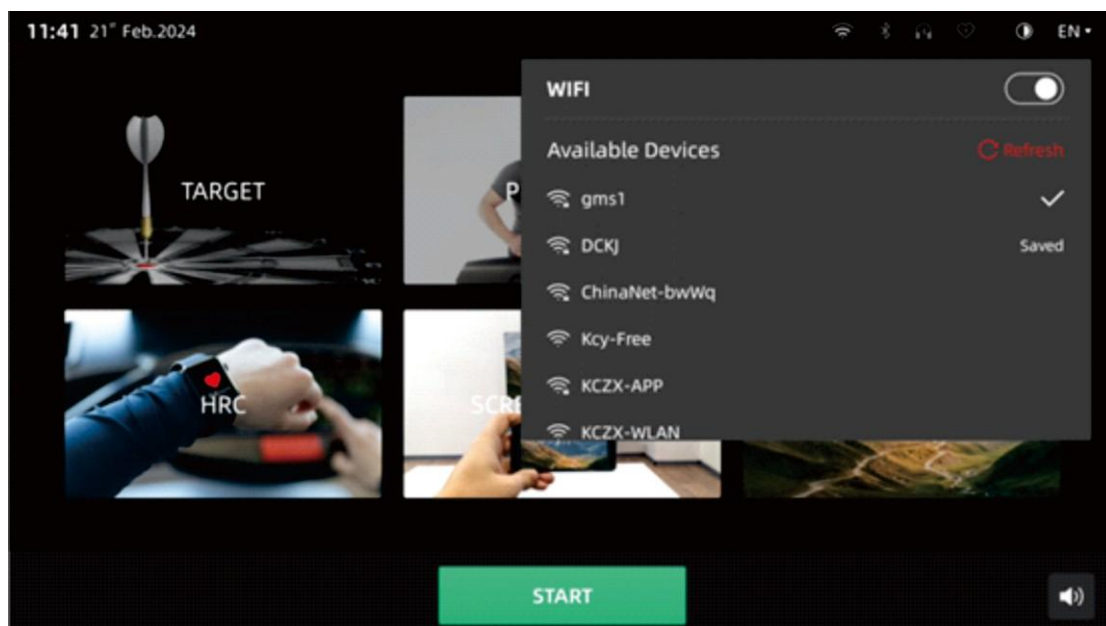

WiFi settings page

USB icon  : When inserting a USB drive, the icon will be displayed. But when removing USB, it will disappear.

Bluetooth Settings

Press the Bluetooth button at the top of the screen to enter the Bluetooth settings page with one click. Press the Bluetooth switch to turn on Bluetooth; press refresh to search for nearby Bluetooth devices. Select the device you want to connect to (only Bluetooth earphones or speakers). If you press other blank spaces, the Bluetooth window will disappear.

Console Panel Functions

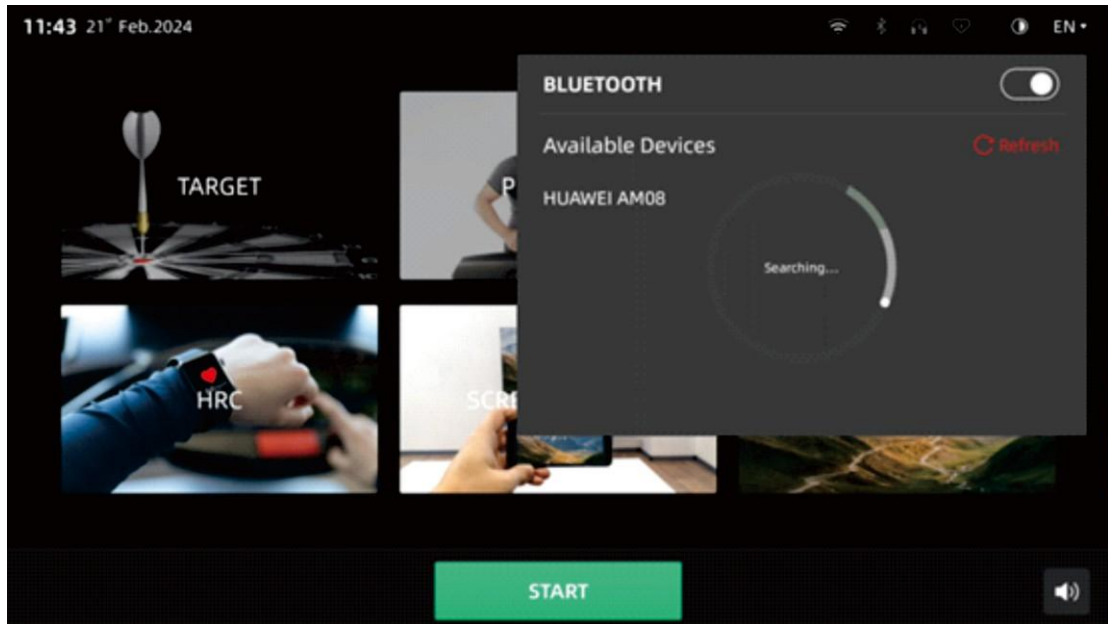

Bluetooth selection

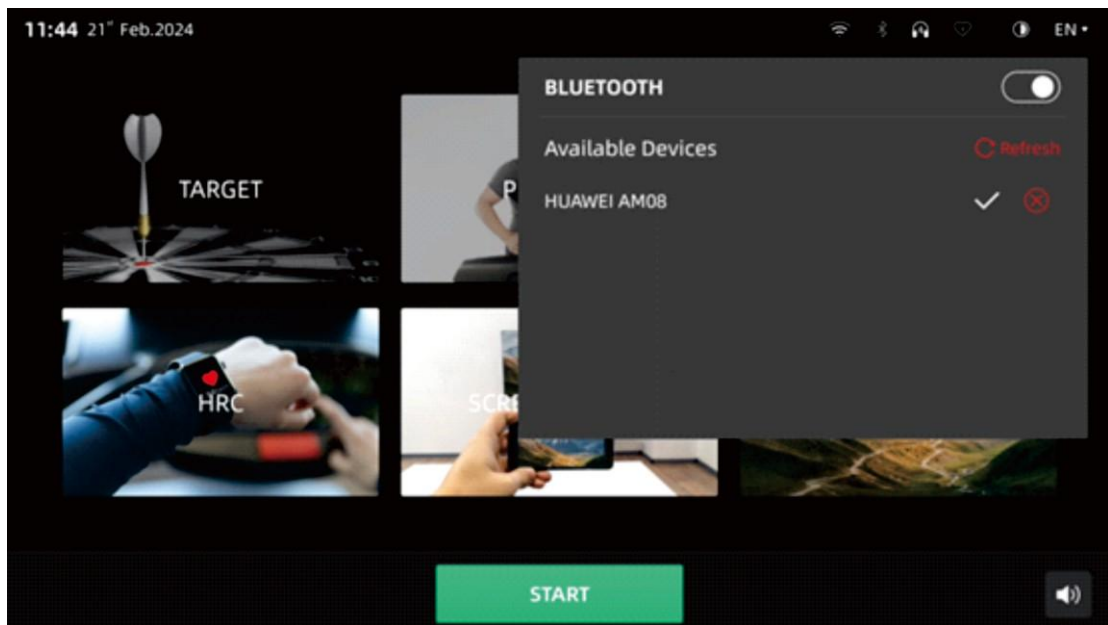

Bluetooth connected

Console Panel Functions

Heart Rate Bluetooth

Press the HR Bluetooth icon at the top of the screen to enter the heart rate Bluetooth settings page with just one click. Press the HR Bluetooth switch to turn on Bluetooth, and select the device you want to connect to. (It can only be a heart rate device or Bluetooth module)

If the Bluetooth module is successfully connected,  the Bluetooth Mac icon will light up and display the connected module Mac. After the Mac address is displayed, regardless of whether the Bluetooth module is connected or if it is replaced with another Bluetooth module, the Mac display will not change. Refreshing is just a decoration. After connecting once, the displayed Mac is basically fixed. Clicking on other blank places will cause the Heart Rate Bluetooth disappear.

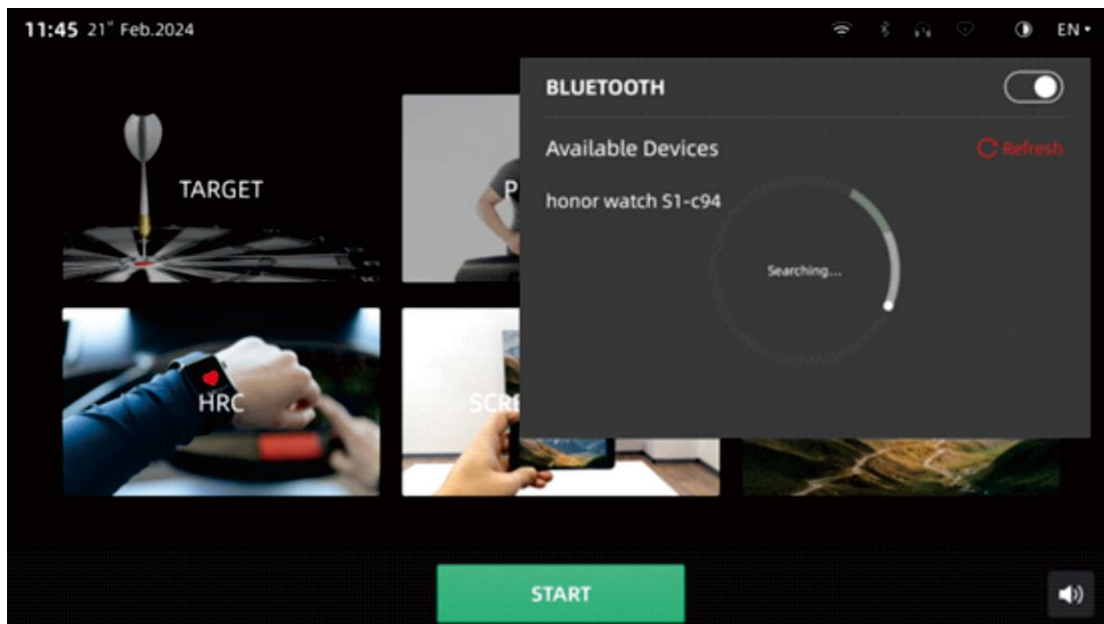

Heart Rate Bluetooth connection

Console Panel Functions

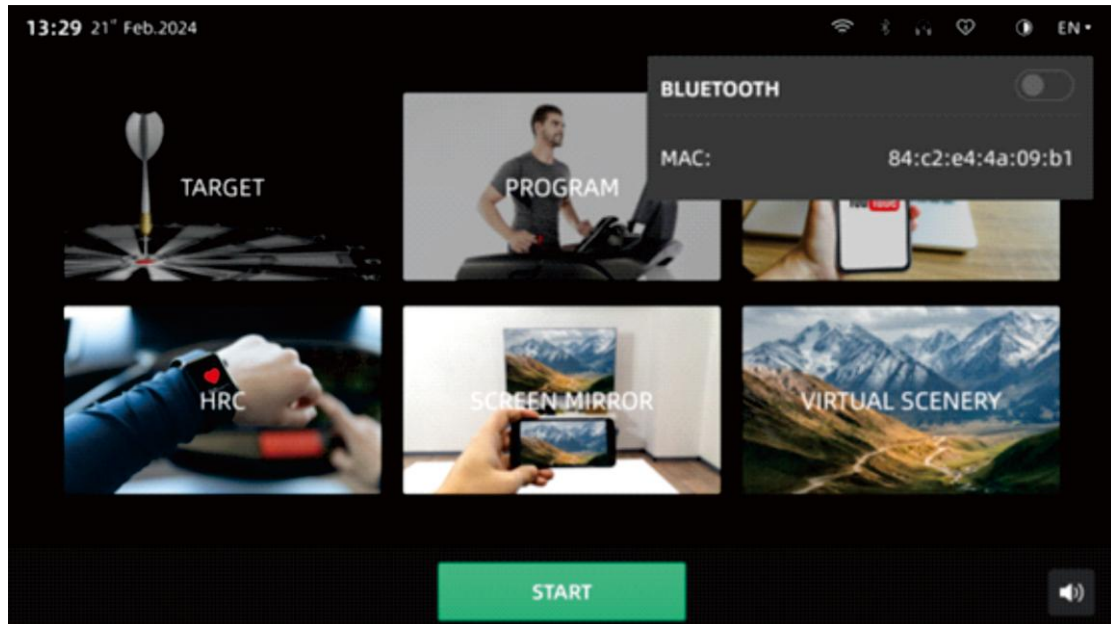

Mac icon

Volume Settings

Press speaker icon to scroll up and down to adjust the volume. If you press other blank spaces, volume adjustment will disappear.

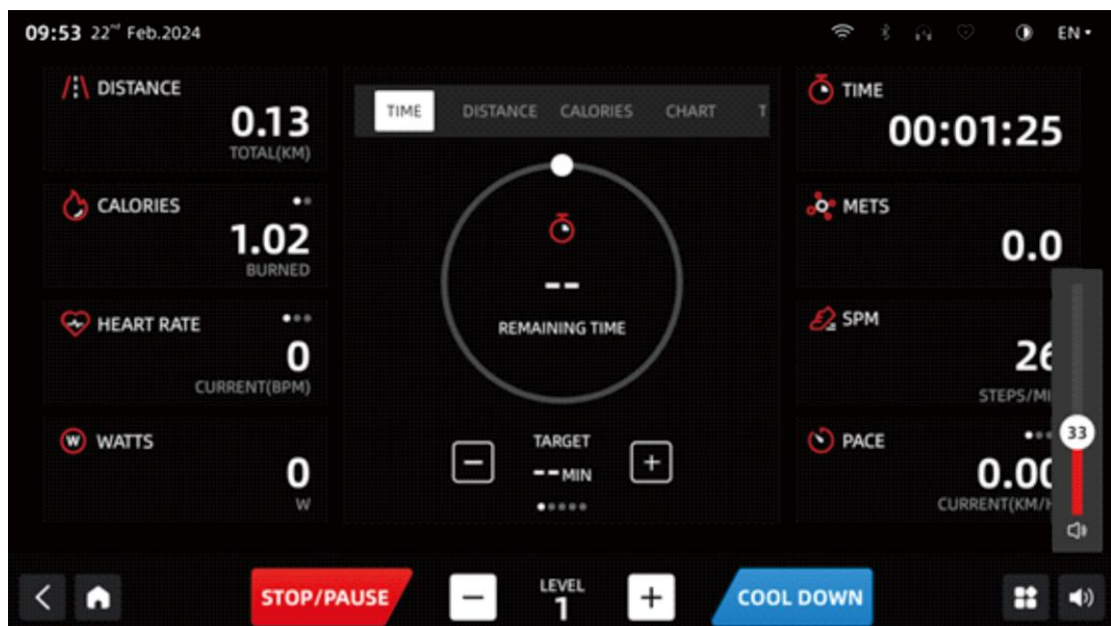

Volume adjustment

Console Panel Functions

Language Switch **ZH ▾**

Switch language among Chinese, English, French, German, Spanish, Portuguese, Italian, Russian, Japanese, and Korean.

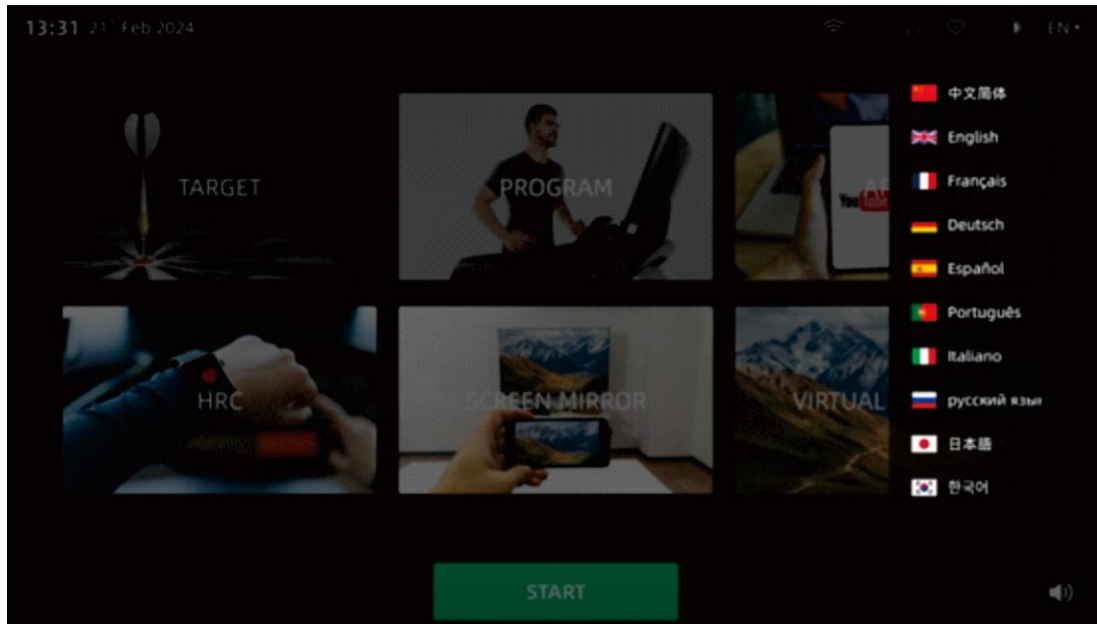

Language switch

Brightness Settings

Press the brightness icon  on the homepage to scroll up and down to adjust the brightness. If you press other blank spaces, the brightness adjustment will disappear.

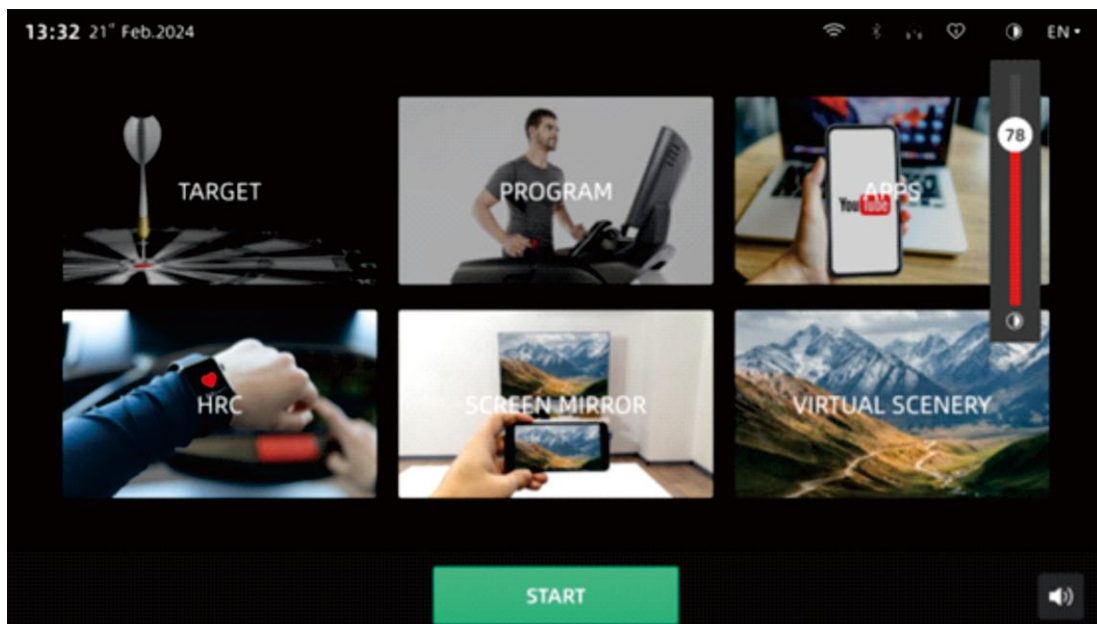

Console Panel Functions

SETTINGS

Continuously pressing above the fixed program will display device information, system reset, factory settings, and software upgrade.

Equipment information: Display the product name, model, screen size, software version, and build version.

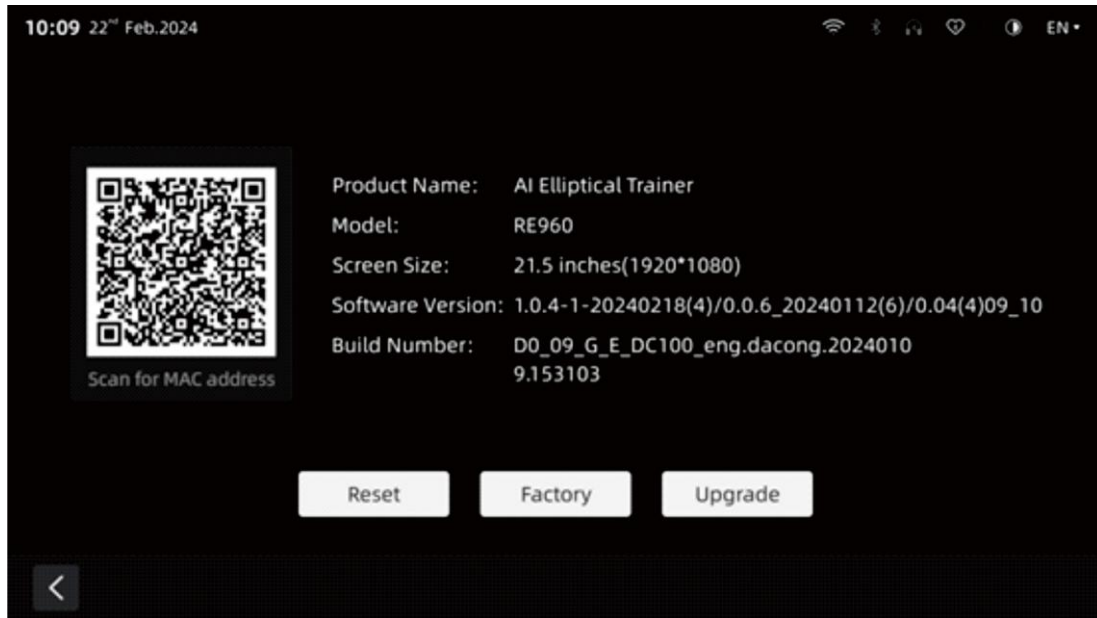

Factory settings

Press Factory and enter the password 90638818 to enter the factory settings.

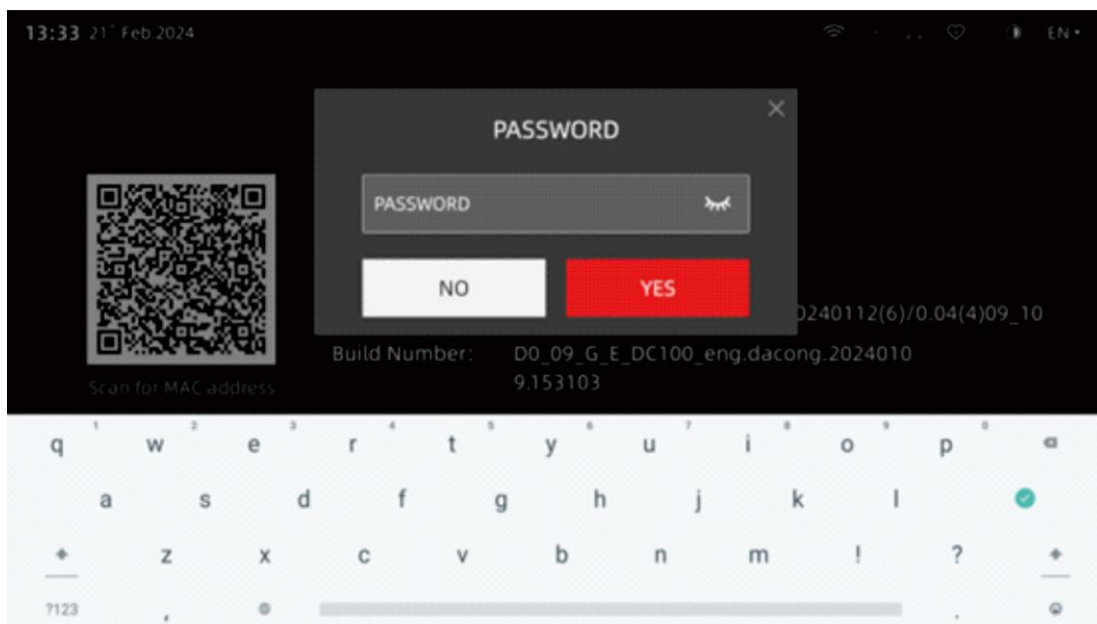

Enter password

Console Panel Functions

Basic Parameters:

Units can be selected in metric or imperial systems, and device models can be RE960, RE970. Press save finally.

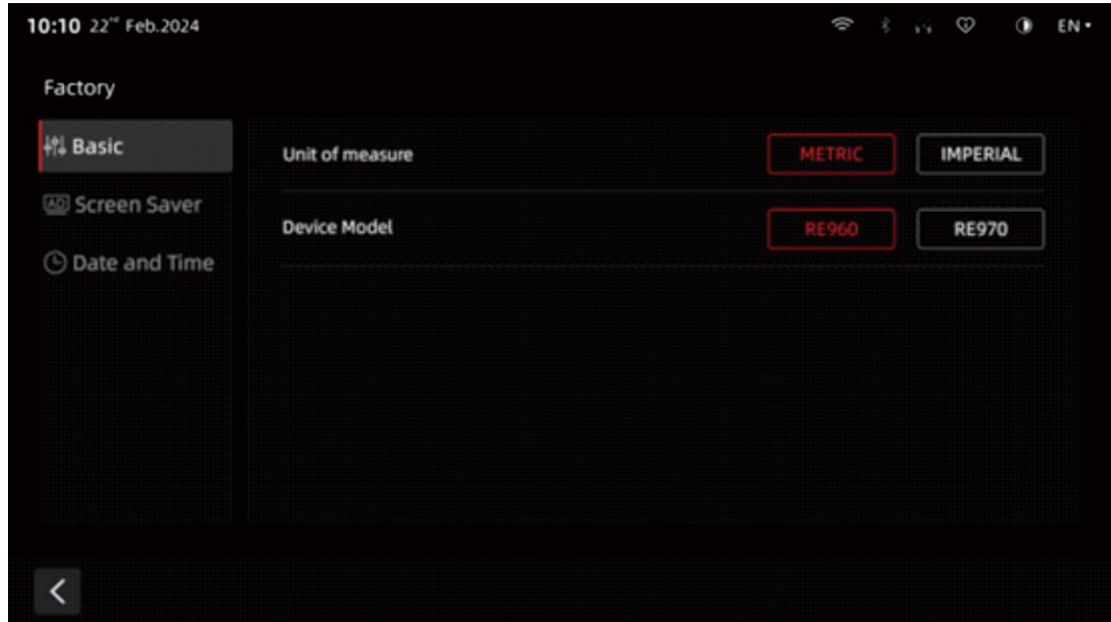

Basic parameters

Screensaver Settings:

Press screensaver settings to set the automatic screensaver advertisement time (30-60 seconds). As long as you don't press the screen, whether you are ride, browsing web pages, To import the advertisement, insert a USB drive with the advertisement path (file name is screensaver, advertisement format is jpg. or png.), then press import; and it will import successful. Press delete to delete the advertisement.

Console Panel Functions

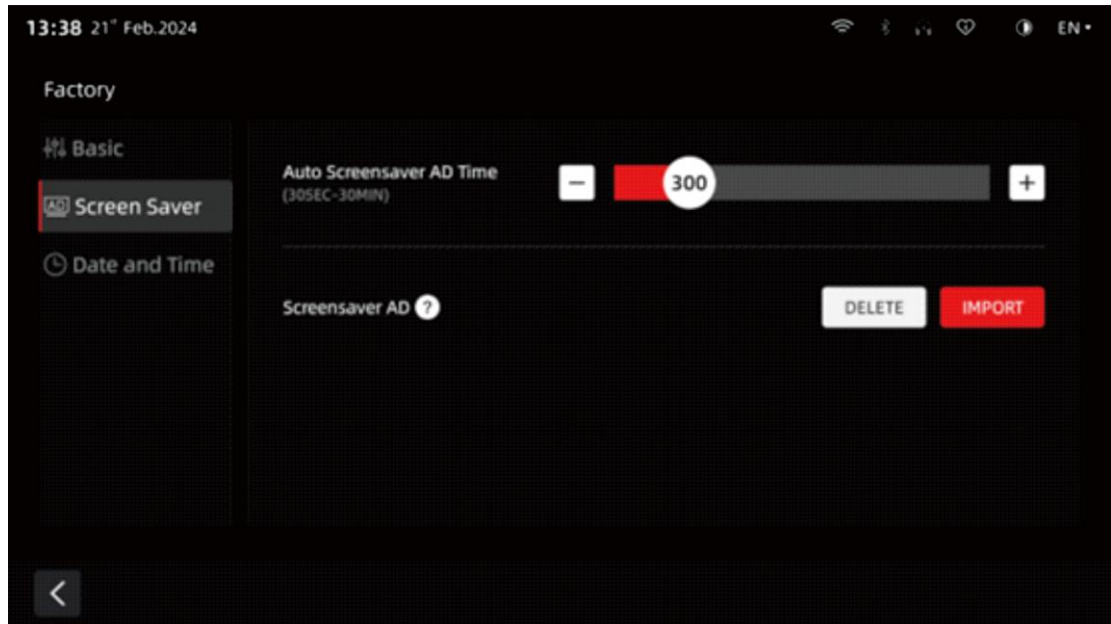

Screensaver settings

Time and Date:

Press time and date to choose whether to automatically set the time (internet connection is required). Press Select Time Zone to select the time zone needed.

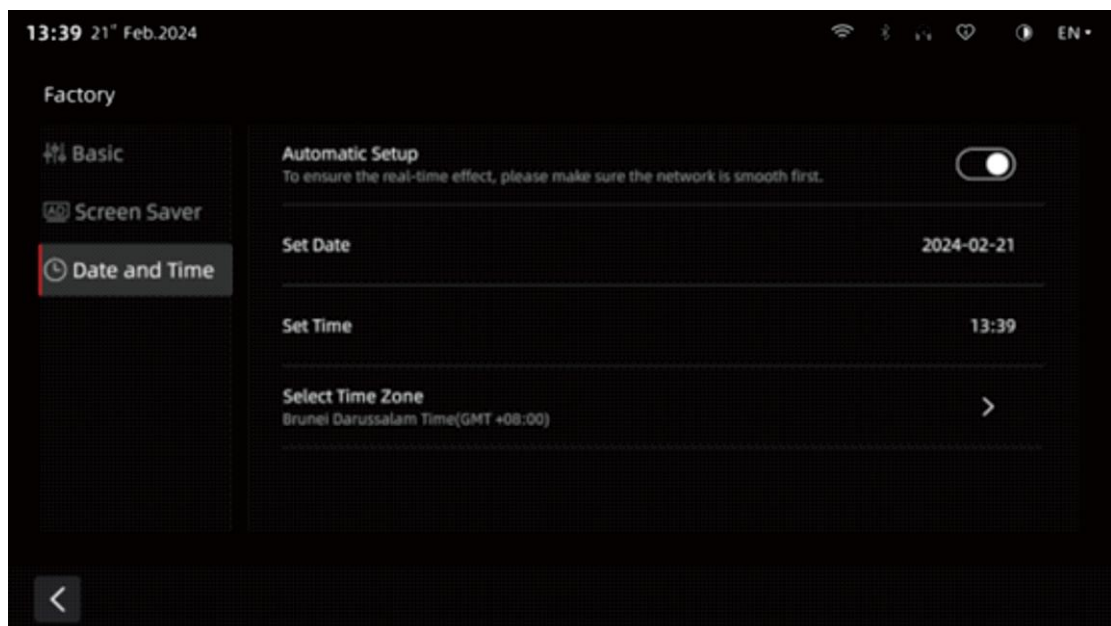

Time and date

Console Panel Functions

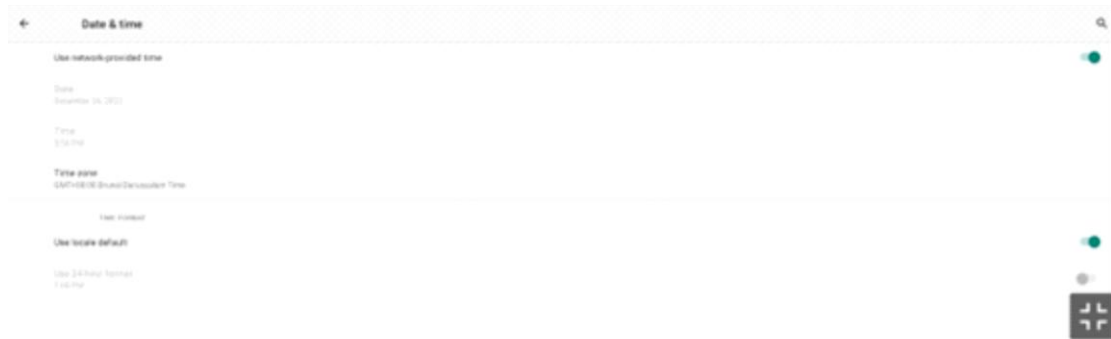

Select time zone

Software Upgrade

Press software upgrade and enter password 90638818 to enter the software upgrade page. This page will display name, current version, server version and operation. If there is a new version, the operation will display upgrade. To upgrade with the USB drive, insert a USB drive with an upgrade path (file name dc_settings), press upgrade; and the upgrade will display successfully.

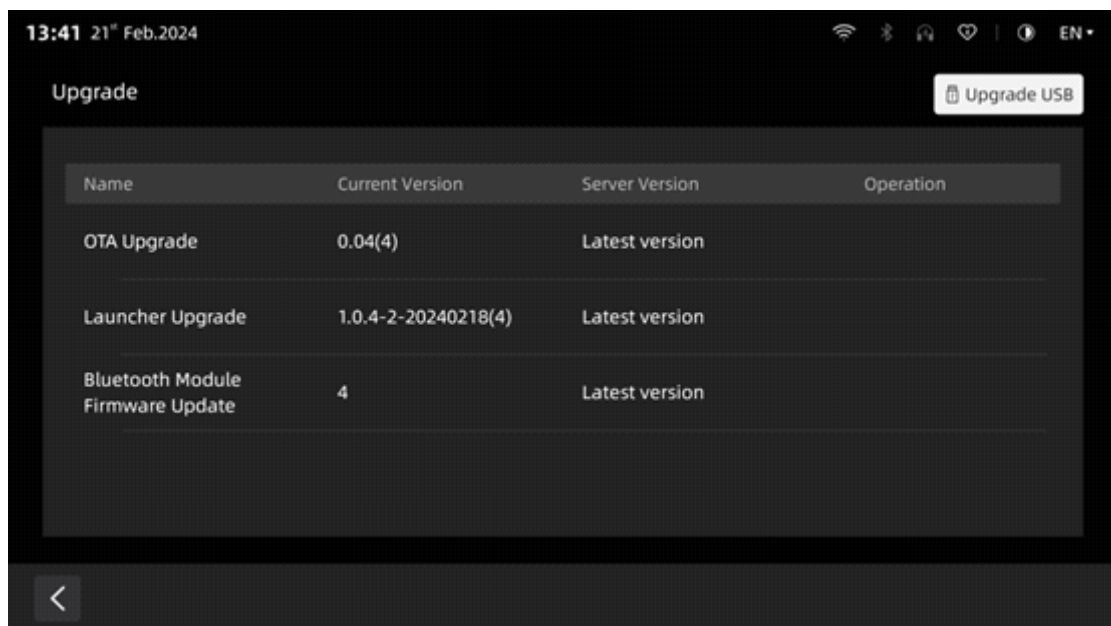

Software upgrade

Console Panel Functions

Reset:

Press system reset and enter password dchealth@2019 to enter system reset settings.

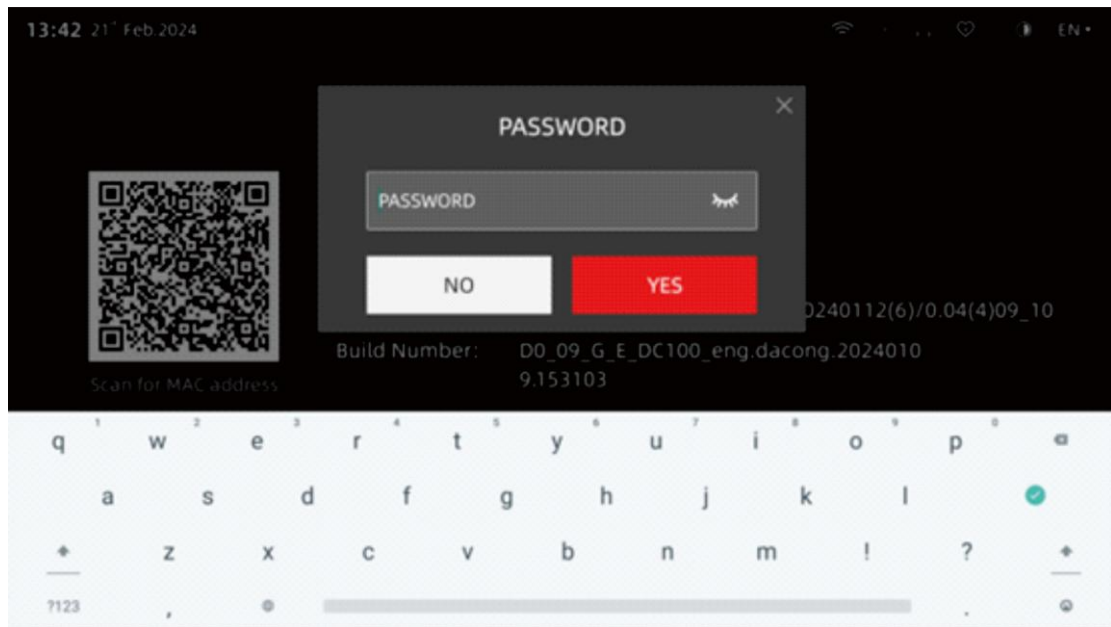

Enter password for system reset

Console Panel Functions

Function Introduction

This treadmill has functions such as total mileage/total time recording, exercise time/distance setting, and maintenance reminders. Users can set their exercise time and distance according to their own needs, and perform maintenance after achieving the set goals.

Maintenance operation instructions

1. Exercise time/distance settings

Enter the "Factory Settings" menu.

Select "Basic Parameters".

Select one of the "Mileage" or "Run Time" options.

Enter and adjust to the desired mileage or time.

2. Maintenance tips and release

When exercise time or distance reaches the set goal, restart the display and it will show "Maintenance Required". Press OK to confirm. When maintenance tips is displayed, please maintain in time, otherwise the maintenance tip will still pop up after power on again. After completing the maintenance, enter Basic Parameters in Factory Settings, click maintained. The equipment will clear maintenance tip. And user can continue to exercise.

3. Automatic brightness switch

Enter the factory settings, click the basic parameters, and the automatic brightness switch can be turned on by default. After opening, the screen brightness will be automatically adjusted according to the brightness of the environment.

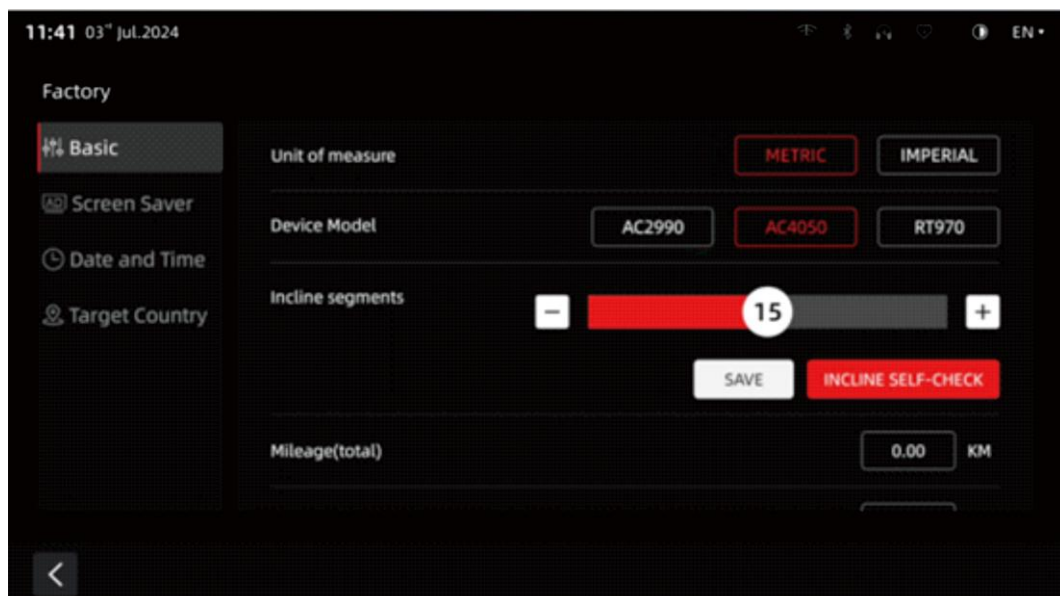

Console Panel Functions

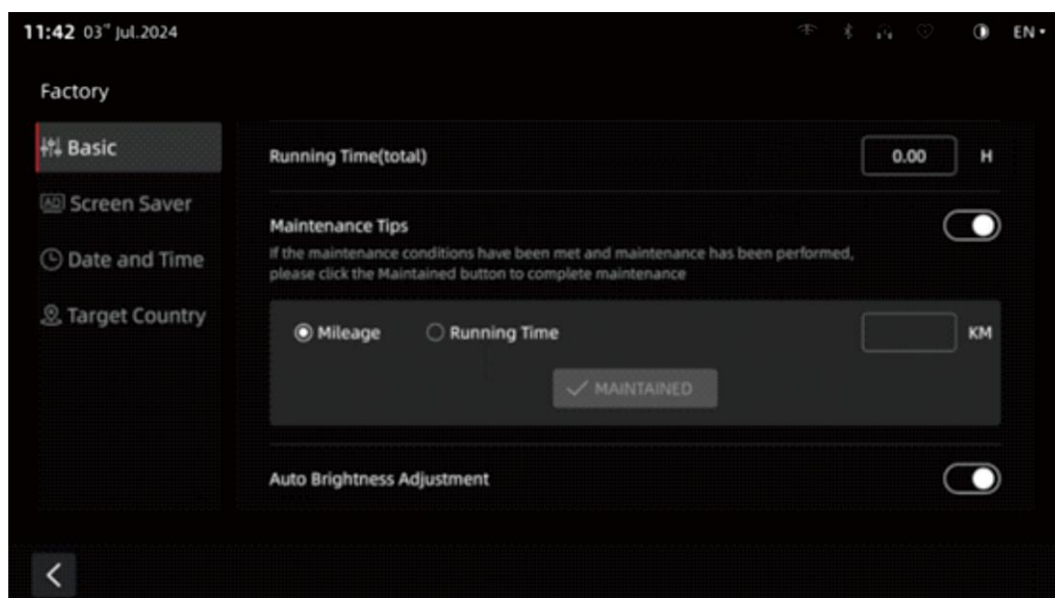

Multi country channel switching function

How to switch channels

Follow these steps to switch the channel settings of the treadmill:

1. Turn on the treadmill

Make sure the treadmill is in standby mode, then press the power button to turn it on.

2. Enter factory settings

Continuously click on the top bar in the middle of the homepage, click on Factory Settings (enter password 90638818), and enter the factory settings interface of the treadmill.

3. Select channel settings

In the shipping country, find "Channel Settings" or similar options.

4. Select the target country/region

In the channel settings menu, you will see a list of channel settings for different countries/regions. Use the up and down navigation buttons to select the channel settings for your target country/region.

Console Panel Functions

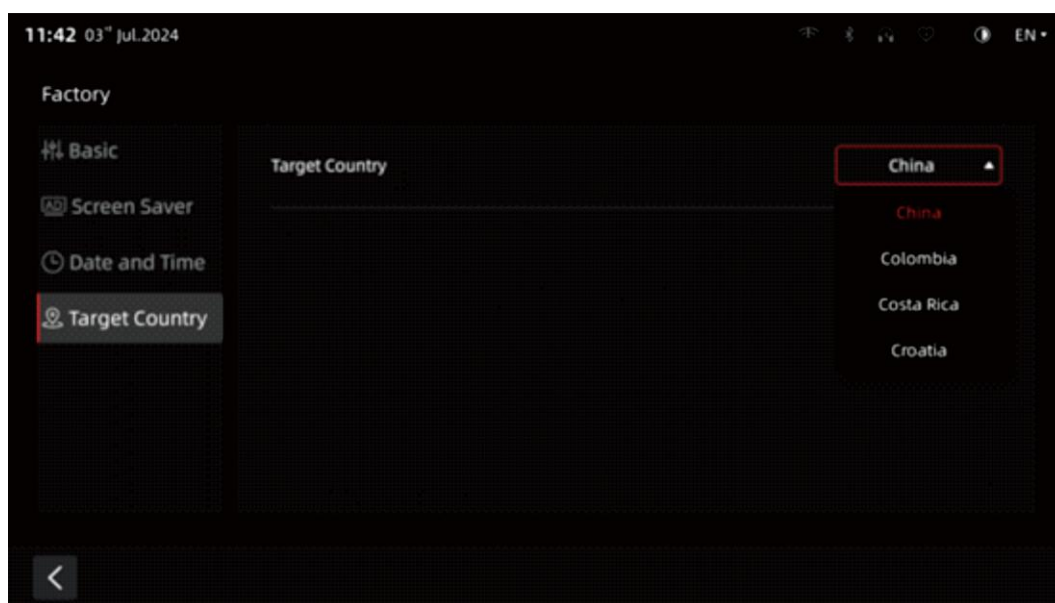
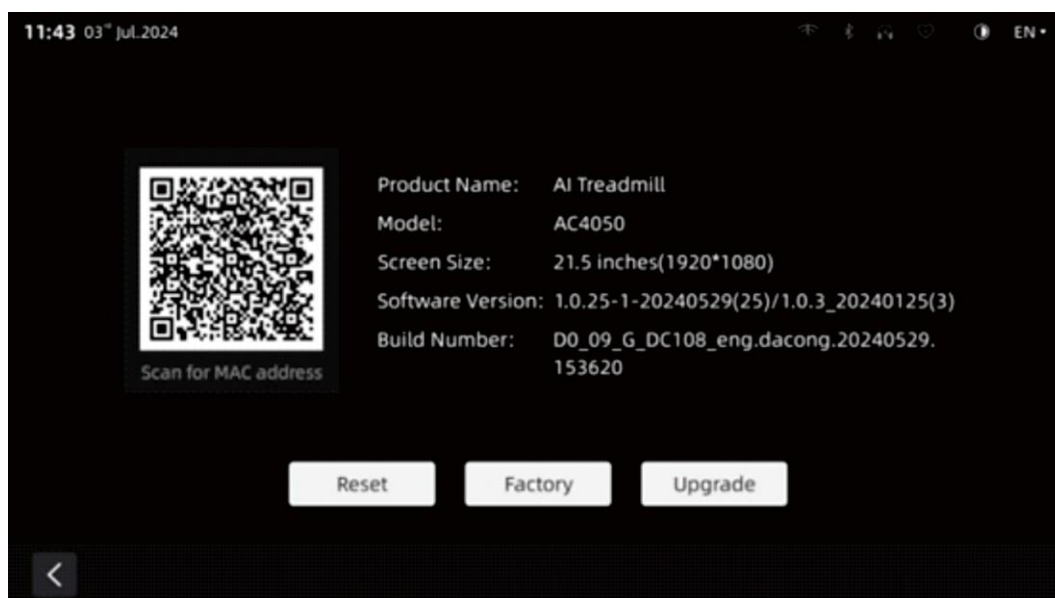

Precautions

The maintenance operation includes cleaning the running belt, checking the tightness of the wires and various components.

Please regularly maintain the equipment to ensure its normal operation and extend its service life.

If the device malfunctions, please stop using it immediately and contact after-sales service.

I hope the above instructions can help you better use and maintain the treadmill. If you have any questions, please refer to the detailed manual or contact customer service.

Troubleshooting Guide

Malfunction	Causations and Adjustment
1. Belt slips or is not on the centered on rear roller	a. Adjust the tension spring
	b. Regulate the tension board
	c. Replace the belt
	d. Call customer service
2. Noise	a. Check hybrid
	b. Check bolt and bearing
	c. Check driver
	d. Call customer service
3. The console no power	a. Check all cable if loose or deflection
	b. Replace the console
	c. Replace the controller
	d. Check the power adapter
	e. Call customer service
4. Small resistance or without resistance	a. Check all belt if loose or deflection
	b. Check all cable if loose or deflection
	c. Replace the console
	d. Replace the controller
	e. Replace hybrid
	f. Call customer service
5. Pedal become flexible	a. Tighten the pedal with spanner
	b. Replace the pedal
	c. Replace the crank
	d. Call customer service

Electrical Connection

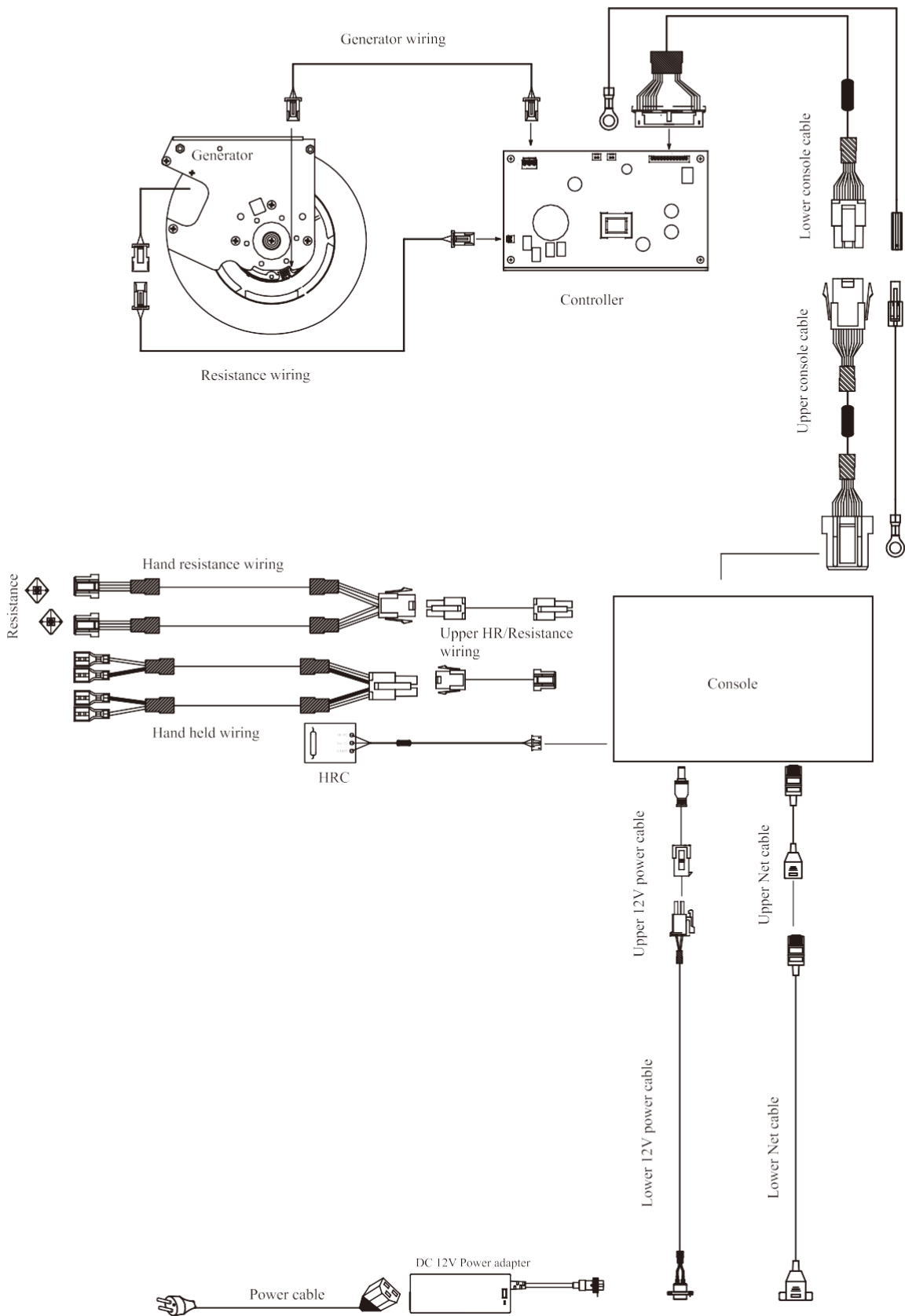

Maintenance Check List

PREVENTIVE MAINTENANCE SCHEDULE						
CARDIO						
<i>Item</i>	<i>Daily</i>	<i>Weekly</i>	<i>Monthly</i>	<i>Quarterly</i>	<i>Biannual</i>	<i>Annual</i>
<i>Mounting Bolts</i>					Inspect	
<i>Frame</i>	Clean				Inspect	
<i>Power Cord</i>			Inspect			
<i>Display Console</i>	Clean		Inspect			
<i>Cover</i>	Clean					
<i>Handlebar</i>	Clean					
<i>Seat</i>	Clean					
<i>Pedal</i>	Clean	Lock				
<i>Belt Tension</i>				Inspect		
<i>Belt</i>					Inspect	
<i>Lubricate Sliding Bearing and Linear Bearing</i>			Inspect			